

the **WaterDrop**

The Bartlett School of Architecture  
MEng Engineering & Architectural Design  
BARC0131 Design Practice 1 Project 2  
Isaac Wang

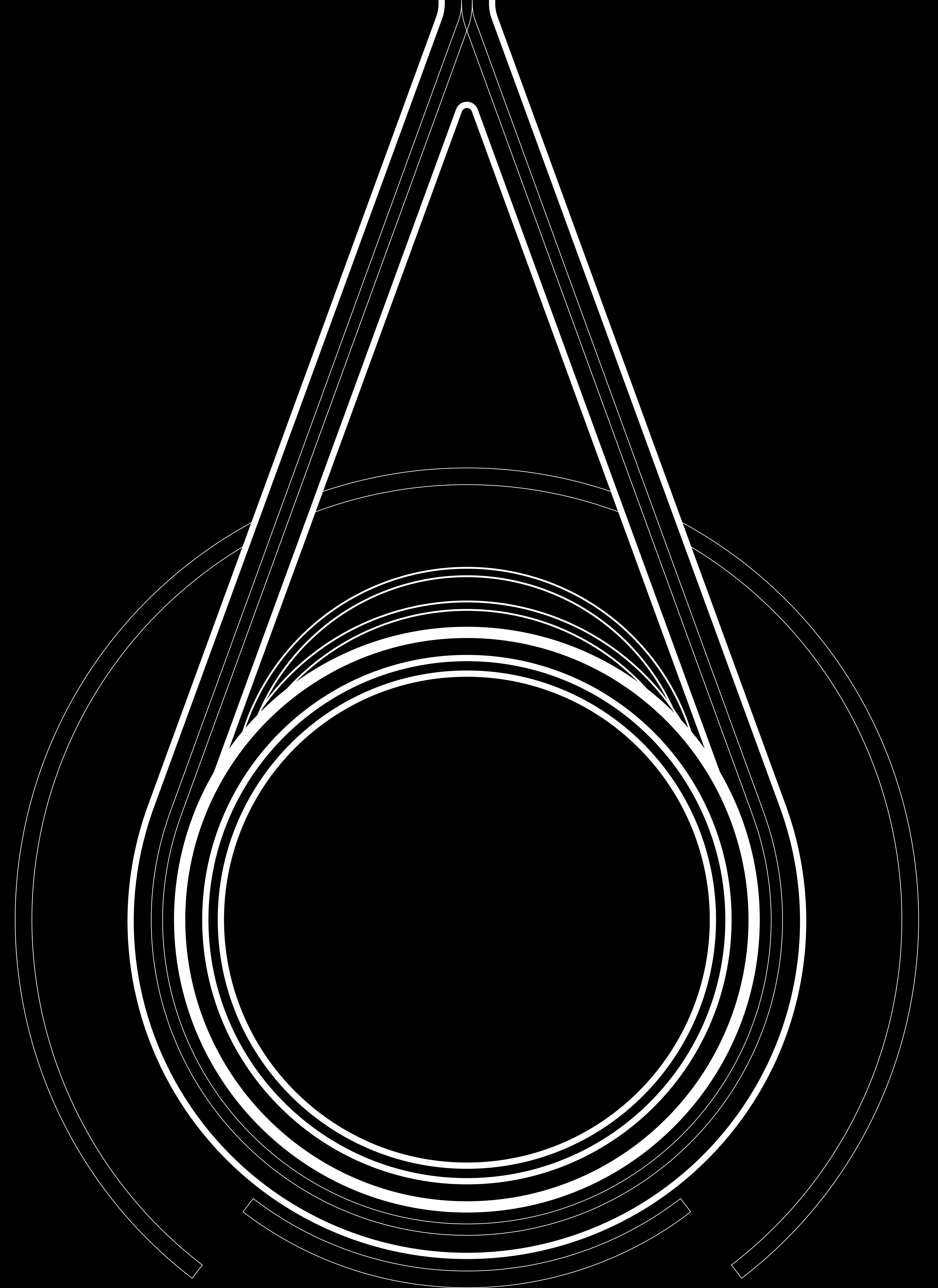



## Manifesto & Narrative

Dungeness is served by a standalone railway system with its aged terminal station located apart from the coast. Despite being seaward, Dungeness lacks pier. Its beach with a depth of over 150 meters further shift access to the sea away.

I would like to introduce a new railway station to the current railway system, with a pier combined to achieve instant transfer between train and boat/ferry. Meanwhile, other than providing a pier to Dungeness, such station constructed in the sea offers more access to the deeper sea area, also access to adjacent towns with piers via waterway, more just a hub for tourists to access different transportation method and sea area far from the coast.

Fagin from Oliver Twist! was the character I have chosen as the narrative of the project. Although being a villain by abetting homeless children to commit crimes, he took care of these children using the treasury taken from the street. He uses neighbouring resources to shield and build a comfortable environment for his dependents.

The structure I design uses water cooling system to maintain the temperature for the passengers inside, matching Fagin's conduct.

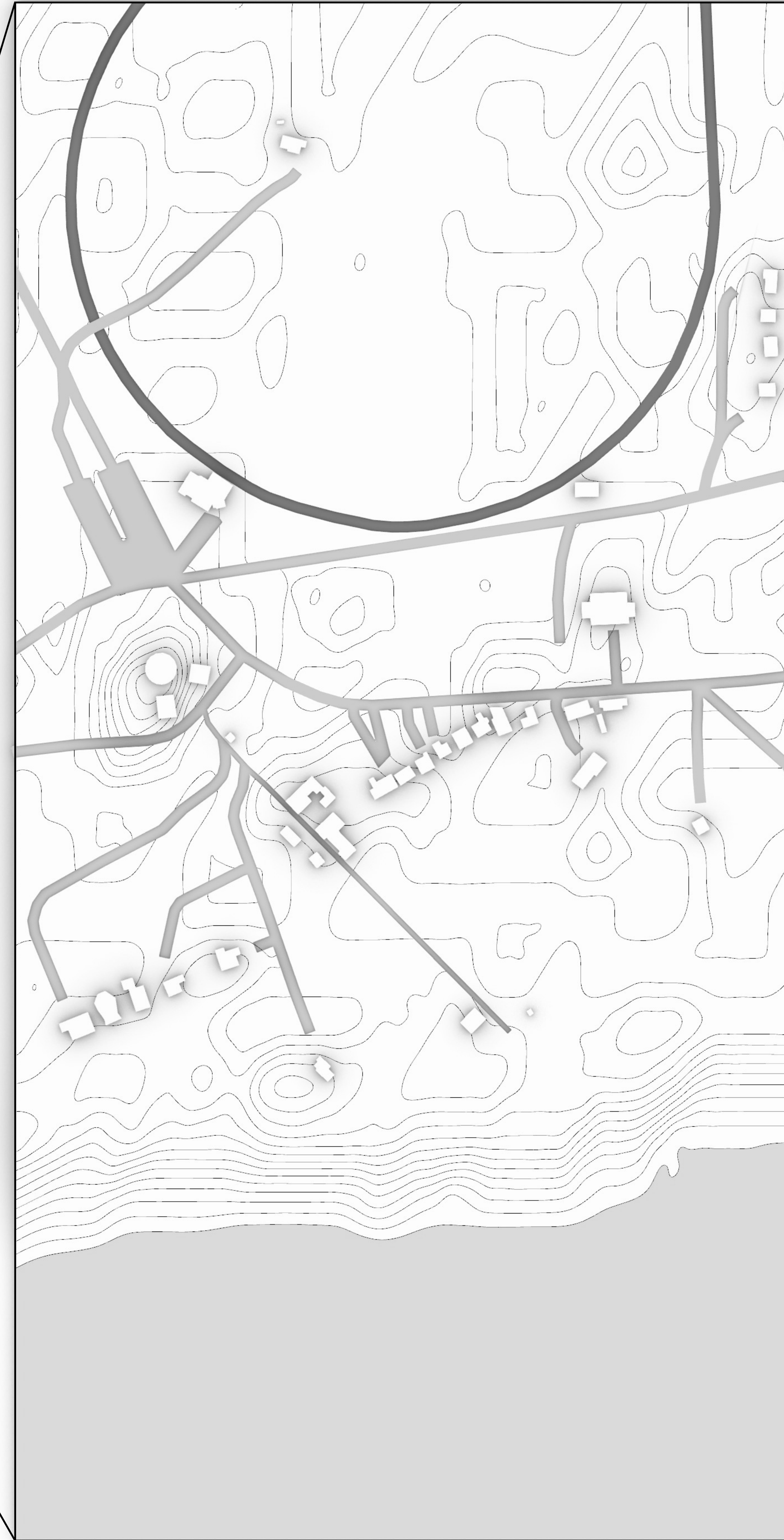

Original Site

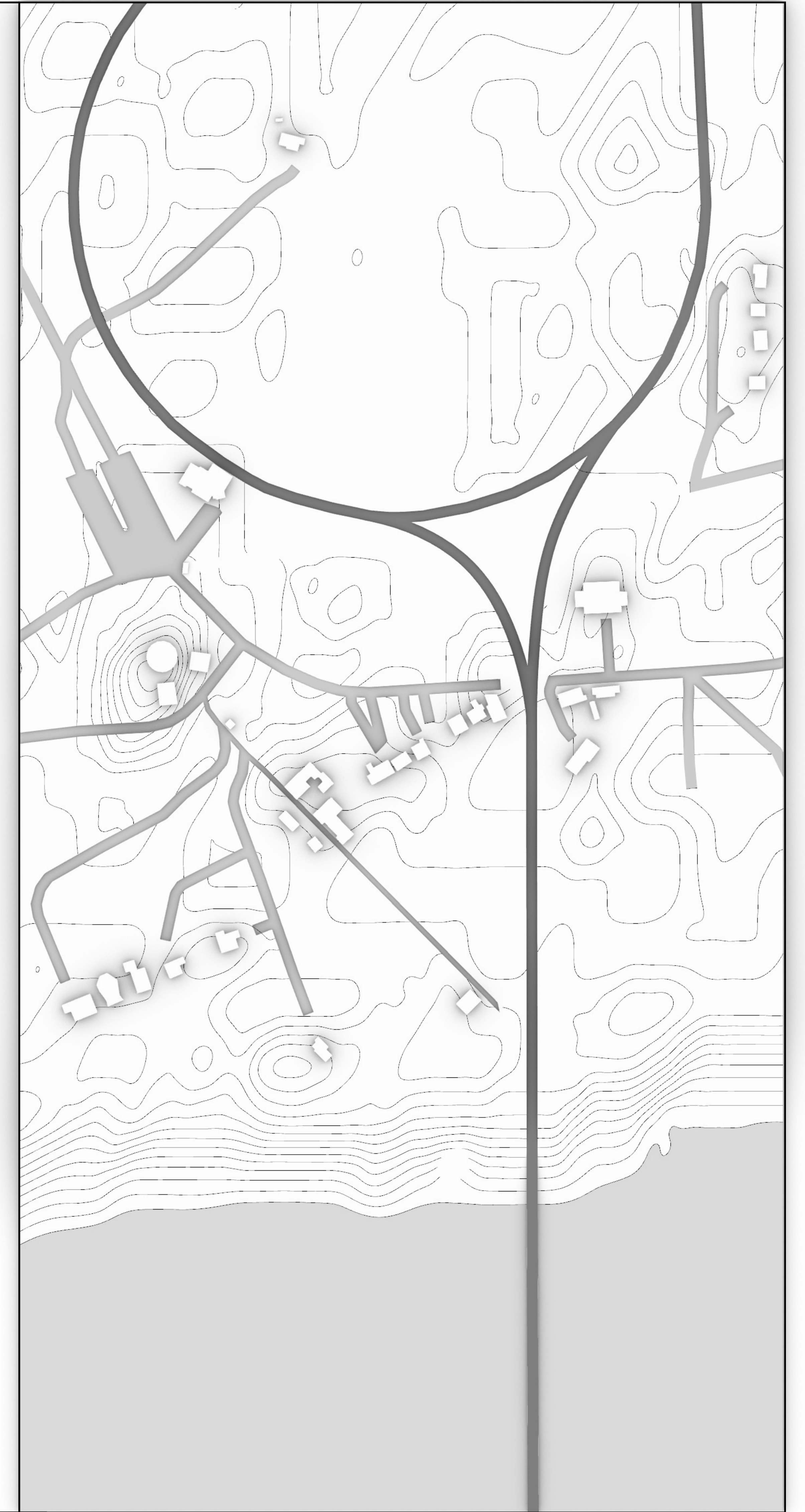

Proposed Site

The rounding part of the railway system is the best location across the entire line to be modified to add a new terminal station, which is the reason for picking this specific site in Dungeness.

The loop is to be extended south into the sea without breaking the rounding system. The train operates in anti-clockwise, then goes through the west part of the extension and head to the new terminal station. The train goes in another loop around the new terminal station and returns, which then joins to the original rounding system via the east extension. The extension will diminish the main branch and one of the other branches of Dungeness Road.

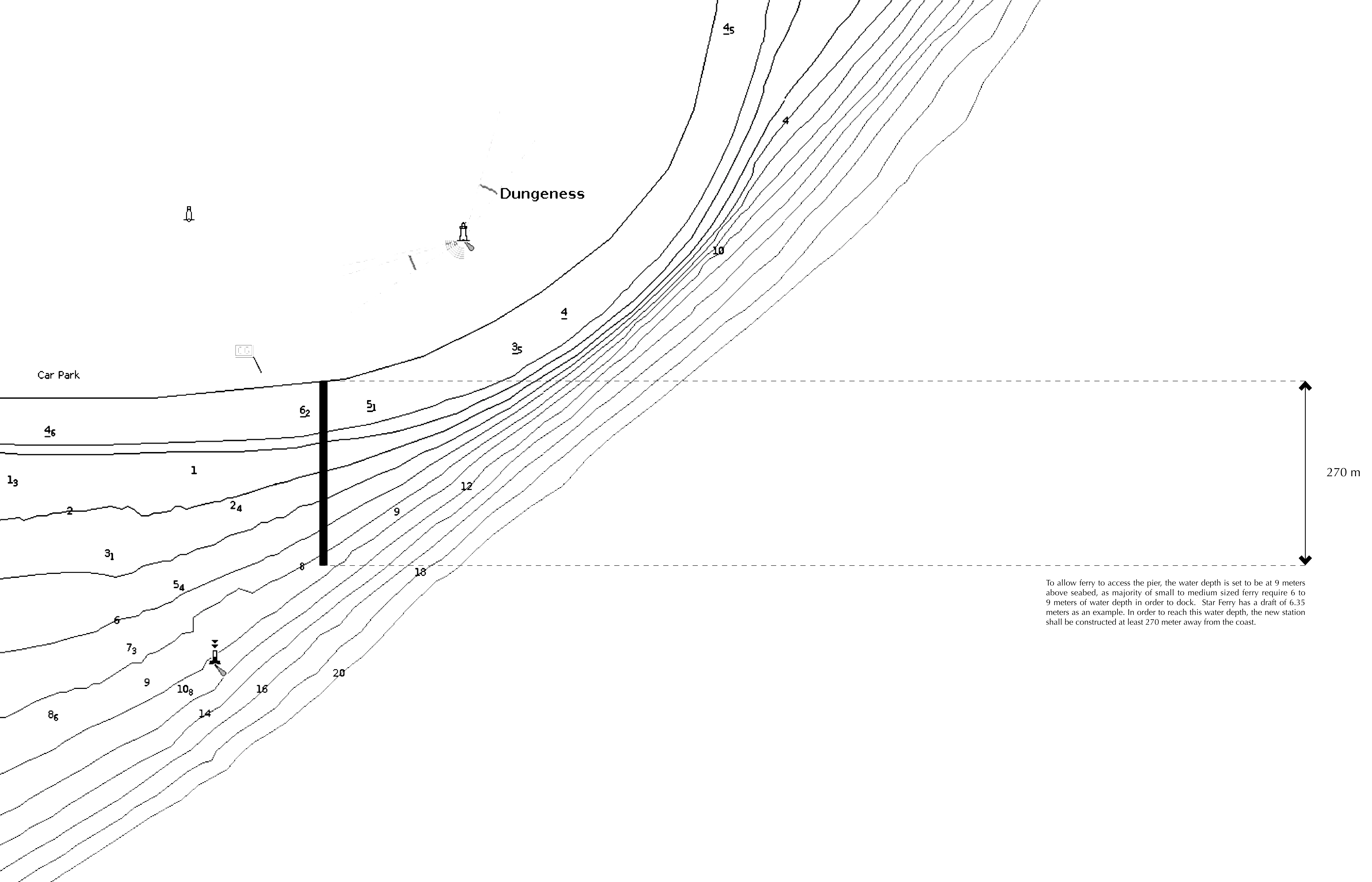

To allow ferry to access the pier, the water depth is set to be at 9 meters above seabed, as majority of small to medium sized ferry require 6 to 9 meters of water depth in order to dock. Star Ferry has a draft of 6.35 meters as an example. In order to reach this water depth, the new station shall be constructed at least 270 meter away from the coast.

## Typology 1: Füssen Station, Germany

Füssen is a small town with a population of around 15,000, located at the southend border of Germany. Füssen station is a terminal station of a normal train line service. New Swan Stone Castle located nearby is the main 'attracting feature'.

This town is similar to Dungeness in terms of population (small), location (border), train station type (terminal station), and main financial income (tourist).

A model was constructed for a better understanding of this study case. The parts highlighted in green is consisted by stores, tourist centre, ticket office and leisure. The part highlighted in orange is the roof of the platforms.

They are connected by a footpath, giving direct access from the platforms to the everything necessary for the tourists. This multi-purpose structure forms a community scattered around the station.

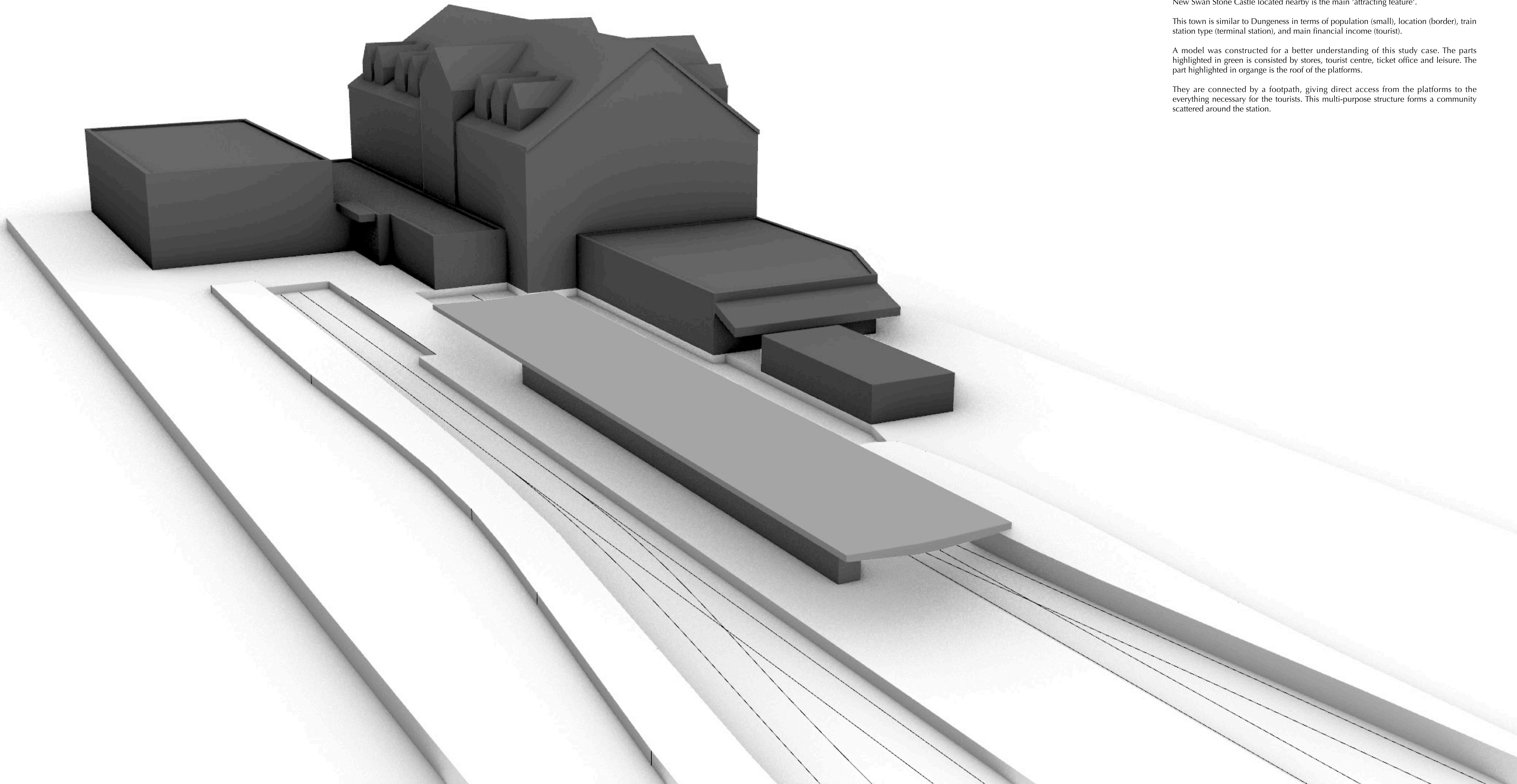

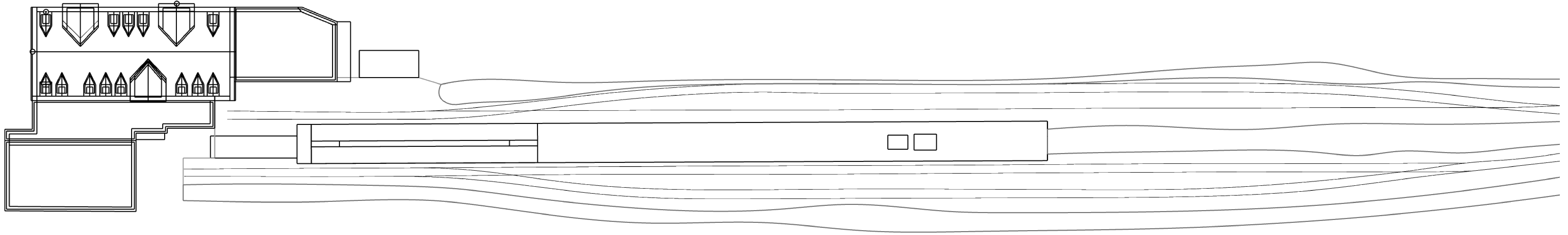

The station has 2 platforms, each platform has an extra railway for emergency or temporary stopping, which is not used frequently. Since it is a terminal station without a rail yard or a rail loop, trains arrive and depart from the same platforms. The station could still operate with 1 platform with 1 railway available, the reason it has 2 platforms is that Füssen is a terminal of one of the branches of a large railway system network, 2 platforms allow more other branches to be linked at the same time.

Dungeness has a stand-alone railway system with a single branch. A similar sized station with only 1 platform and 1 railway is enough. Since there is an existing Dungeness station, if a new train station is to be built, it can become a new terminal station of this railway line. The new station with a similar multi-purpose building like Füssen station could introduce more tourists and increase their travelling experience, which contributes to the local economies.

**Southern Pavilion**  
Multi-function building  
including a cafe and a huge bookable space

**Pier Amusements**  
Mini building with entertainment, restaurants

**Worthing Pavilion Theatre**  
Theatre with the reception of the pier

Worthing Pier is divided into sections. Horizontally, there are 3 sections. The entrance section has the admission built into the Worthing Pavilion Theatre, each attracting the customers from one another. At the middle section is the leisure sector, where Pier Amusements is at. Southern Pavilion locates at the end of the pier. It is a multi-function building. Along with it, is a lower level platform for fishing and sightviewing.

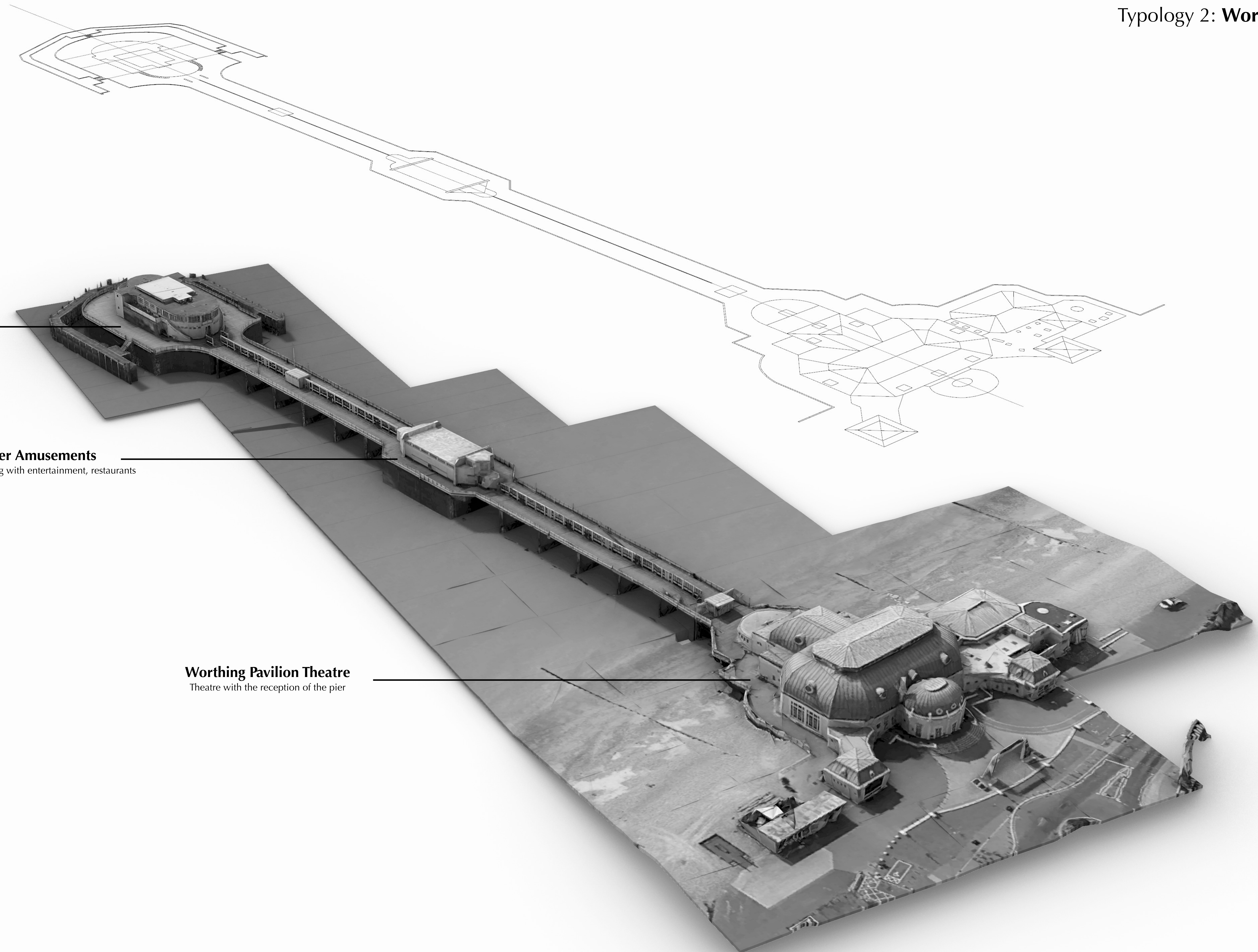

Vertically, the pier is divided into 2 sections to divide the pedestrians. They are divided by boards which contains advertisements and history of Worthing to be read by the pedestrian while they walk. This ensures a regular income for the maintenance of the pier, along with the profit made by the bookable space of the Southend Pavilion.

The lower level platform can be accessed from three stairs, it has potential to be modified to be able to be used as a dock to board boats in the future.

Through this typology, I was inspired by the application of vertical space usage. Division of the pedestrian flow is also another point I could take into my design.

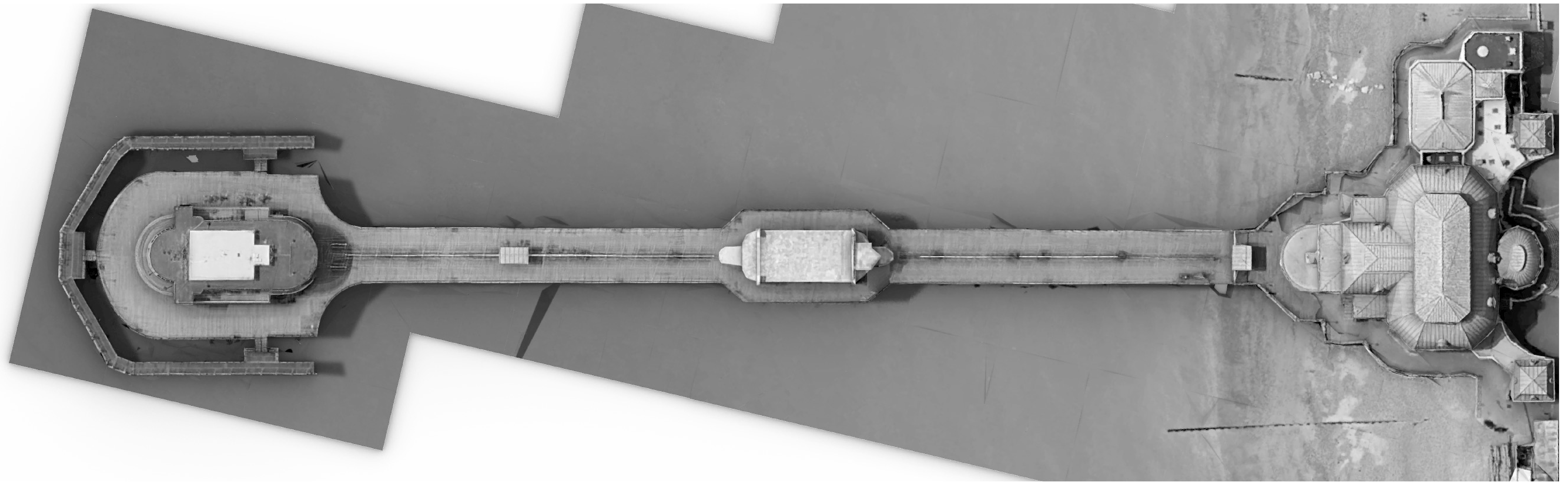
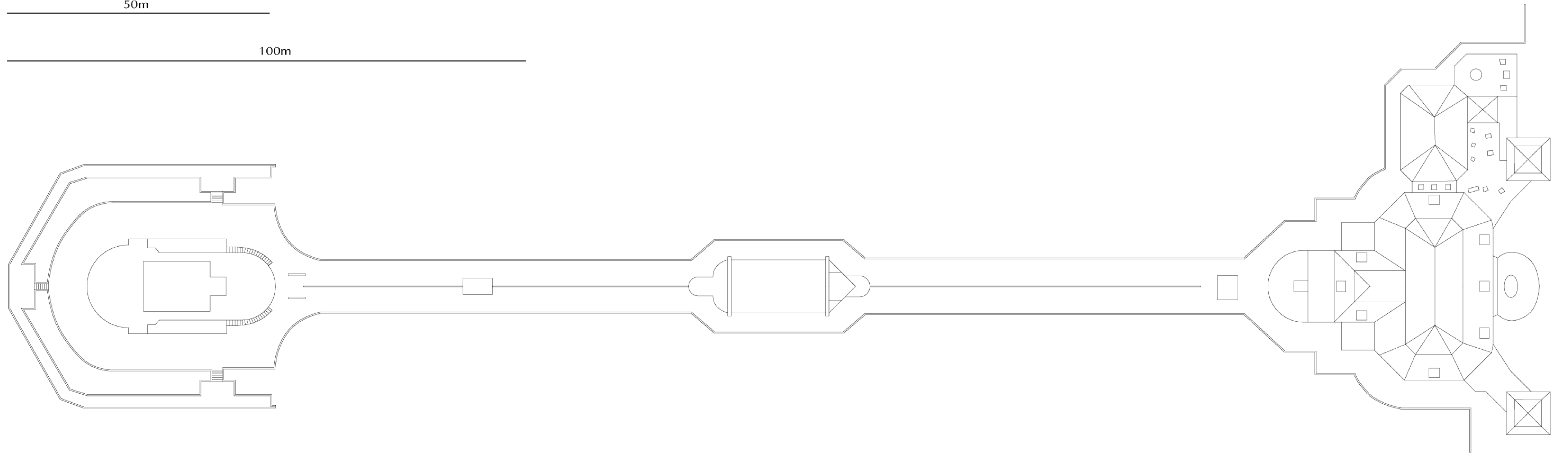
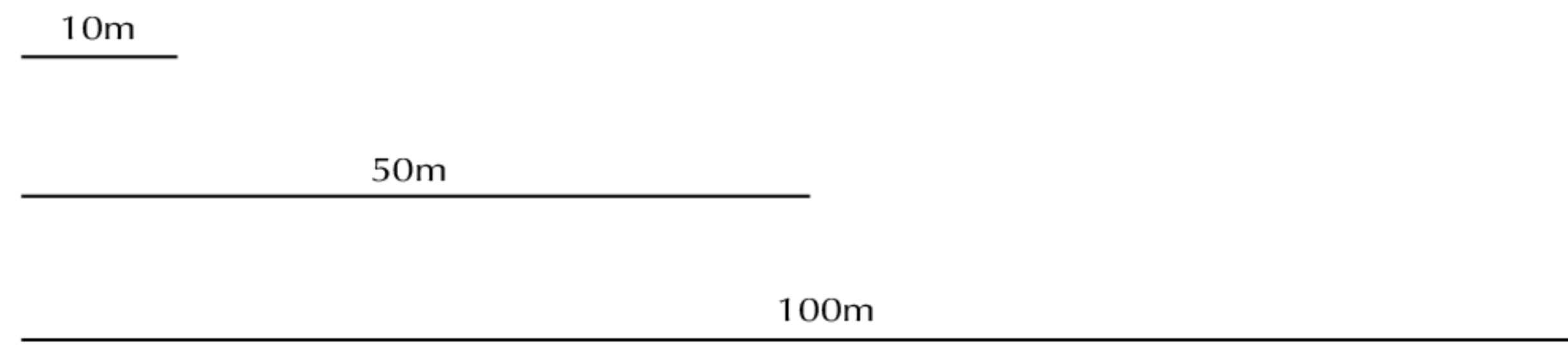

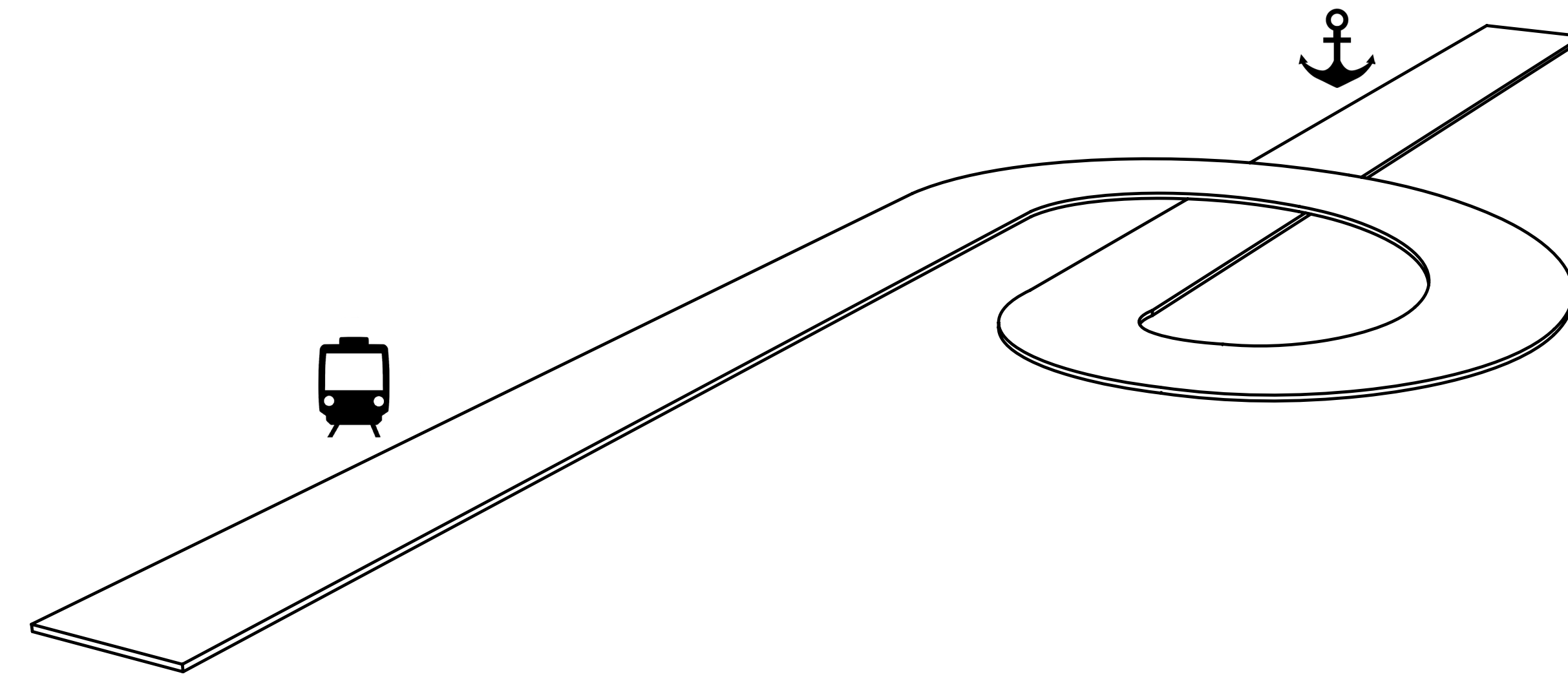

The general shape was initially decided to be as simple as possible, which has a 'belt' shape with a single turn helix connecting the upper train station level and the bottom pier level. It was designed to be a standalone structure with a bridge holding the railway next to it which is not shown here.

Helix ramps were used in order to encourage passengers to walk more on this open structure above deep sea while transferring, as to enjoy more this valuable environment offered by the location of the structure. A helix ramp saves space by going round, also it consistently turns, allowing the passengers to view the surroundings in all directions while moving.

There is no space designed for leisure, ticket hall or any other facilities. Although this design represents 'pure simplicity', it is not practical. As in reality, facilities like toilet, ticket hall, ticket machines are required. It is also not worthy to construct a bridge over 270 meters long to connect such small structure.

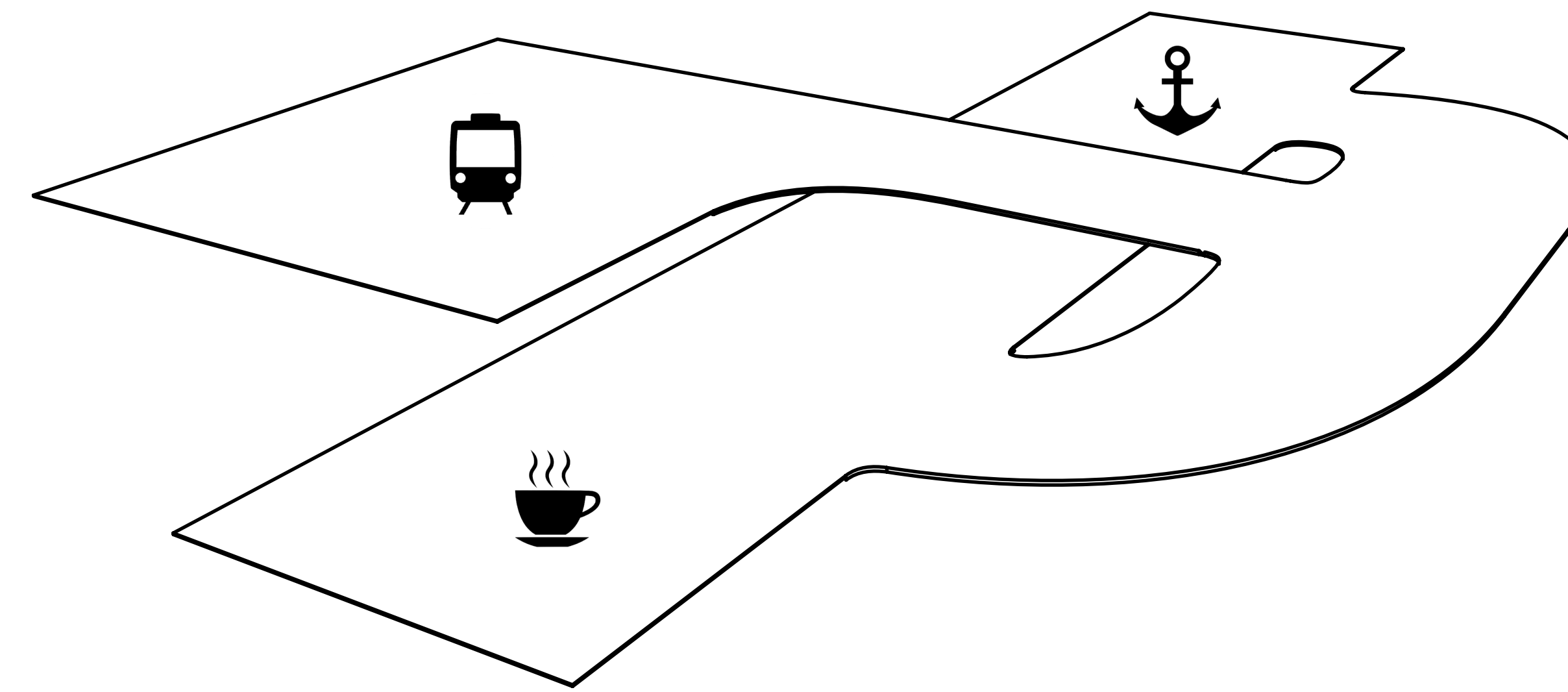

After the first iteration, the areas of the train station and the pier were enlarged. Train station level was connected to the pier & leisure level by an internal bridge, which has two quarter-helix ramps.

Helix ramps were kept for the same reason as in the previous iteration. They also offer a great viewing platform on the end of the bridge. The helix ramps were kept ever since to the final design.

A leisure space was added to the structure, allowing the passengers to rest while waiting for their train/boat. However, it becomes too spacious that the efficiency of usage of material becomes poor. Due to the fact that the ramp shall have a certain small gradient to fit to walk on, which forces the entire structure to be huge in order to match with the helix.

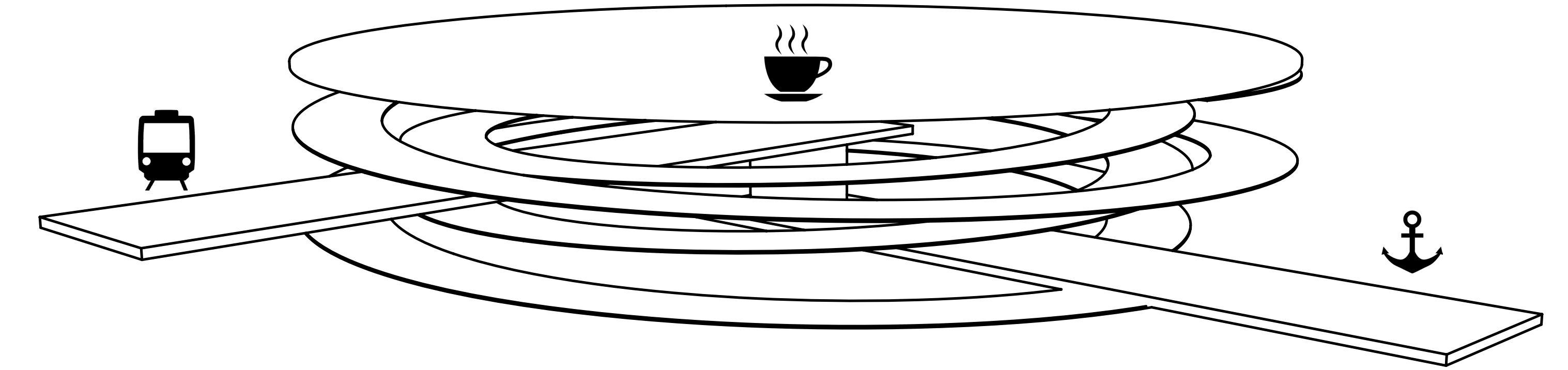

In the third iteration, the train station level, pier level and the leisure level were separate and stacked. Different levels were connected via the lift in the central pillar and the double helix ramps. Stacking offered a much more space efficient, along with the application of double helix, longer ramps allowed the structure to shrink into an acceptable size.

Nevertheless, the positioning of the helix ramps became much more tougher as both shall intersect all levels at the same or similar altitude, which limits the design of the structure. Moreover, placing the leisure level at the top could cause the passengers not to be bothered to visit, as the helix ramps had increased lengths. It would also not make sense to move farer from the platform/pier to wait for train/boat.

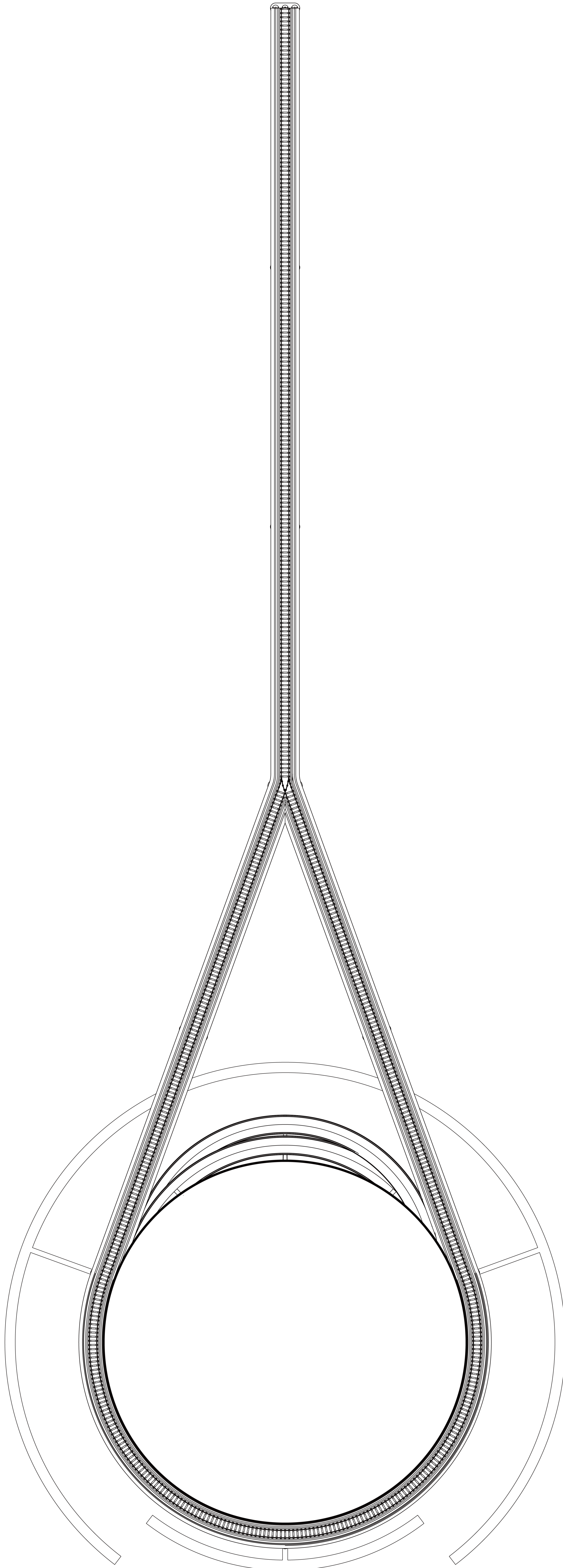

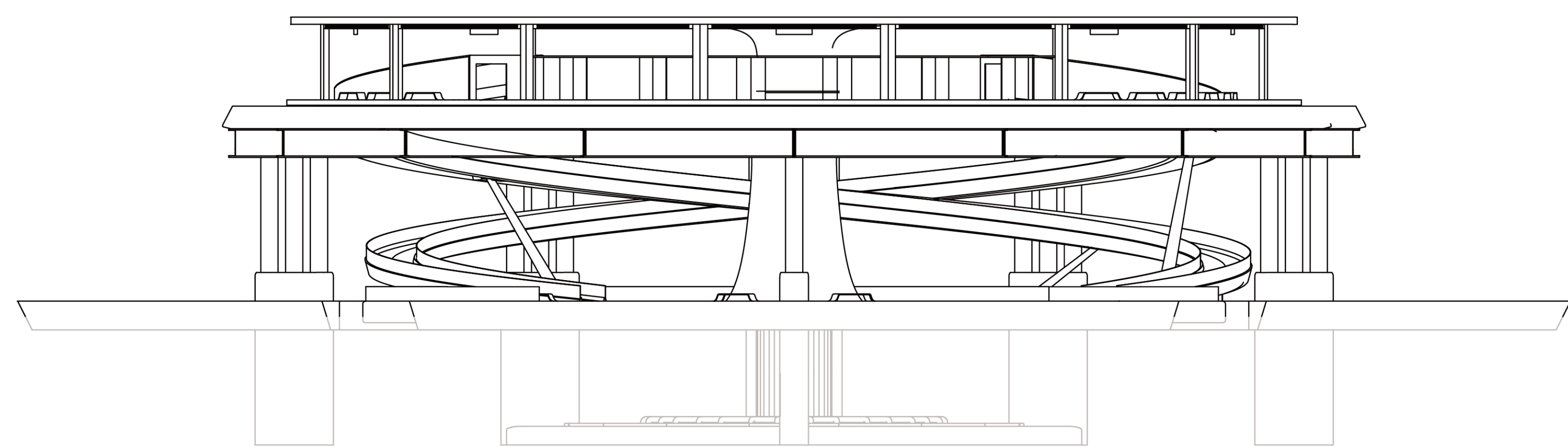

Front View

**Upper Level - Train Station**

Railway

Helix Ramps

**Lower Level - Pier**

Harbour Entrance

Under Water - Foundation

The design comprises a bridge and the main structure. The bridge extends the railway from the coast due south for 150.8 meters, then it diverges and forms a loop. The trains heading to the new station turn into the east diversion to enter the loop, going in clockwise direction, then exit the loop from the western diversion. The loop has a radius of 40 meters.

The main structure is divided into two levels. An upper level containing the train station and a lower level for the pier. Two levels are connected via two one-way helix ramps to diverge passengers heading to for different transportations.

The train station, the upper level is cooled by a water cooling system, which cools the air by cycling the water within the system cooled by seawater at the lower radiators located on the foundation of the main structure under water shown in dimmer curves.

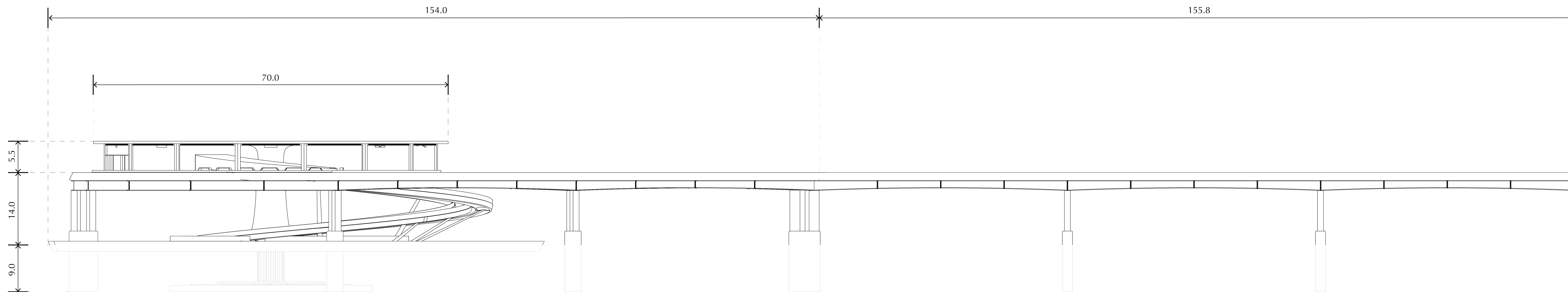

Elevation View

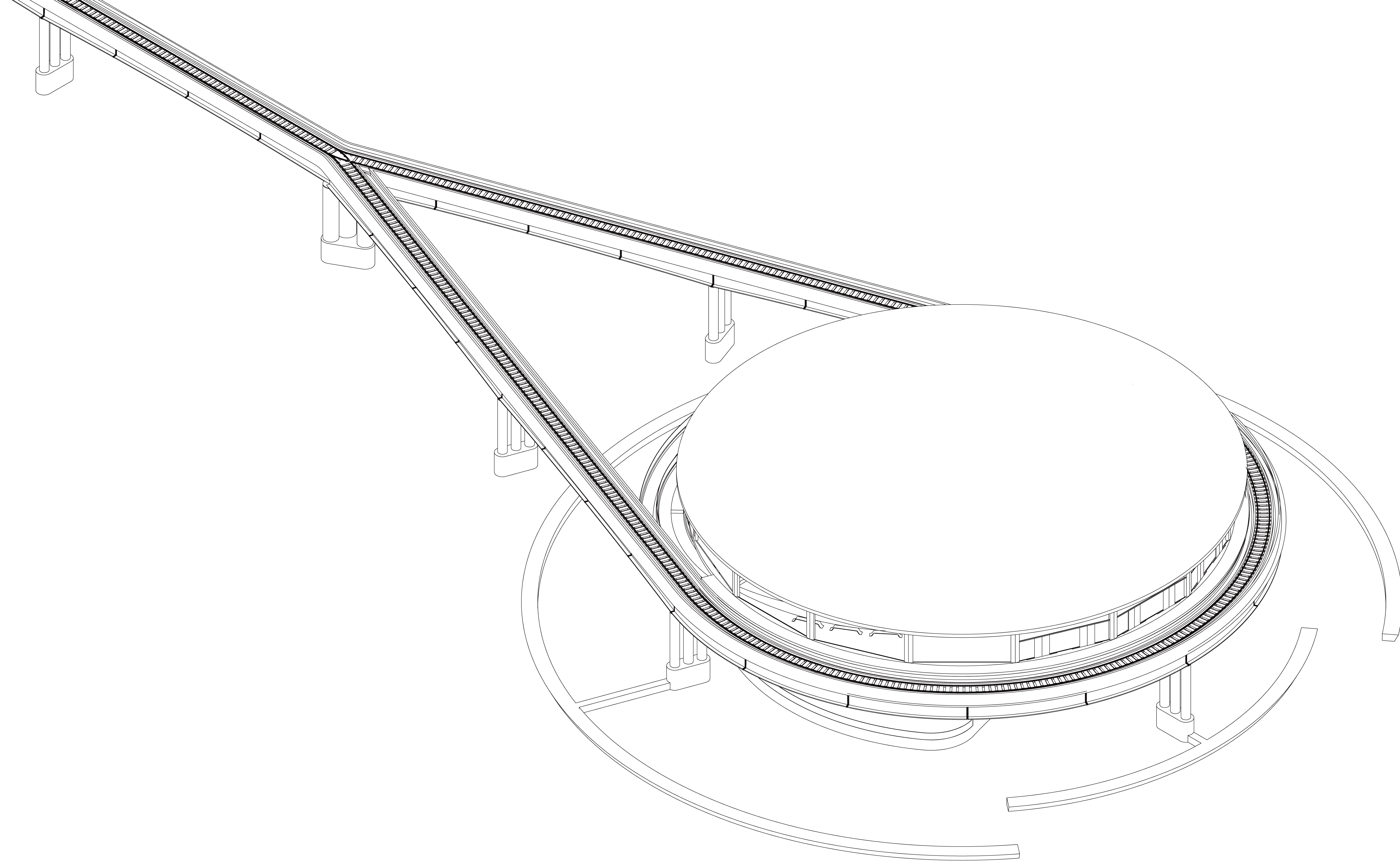

**Isometric View**  
Above Water - Roof Level

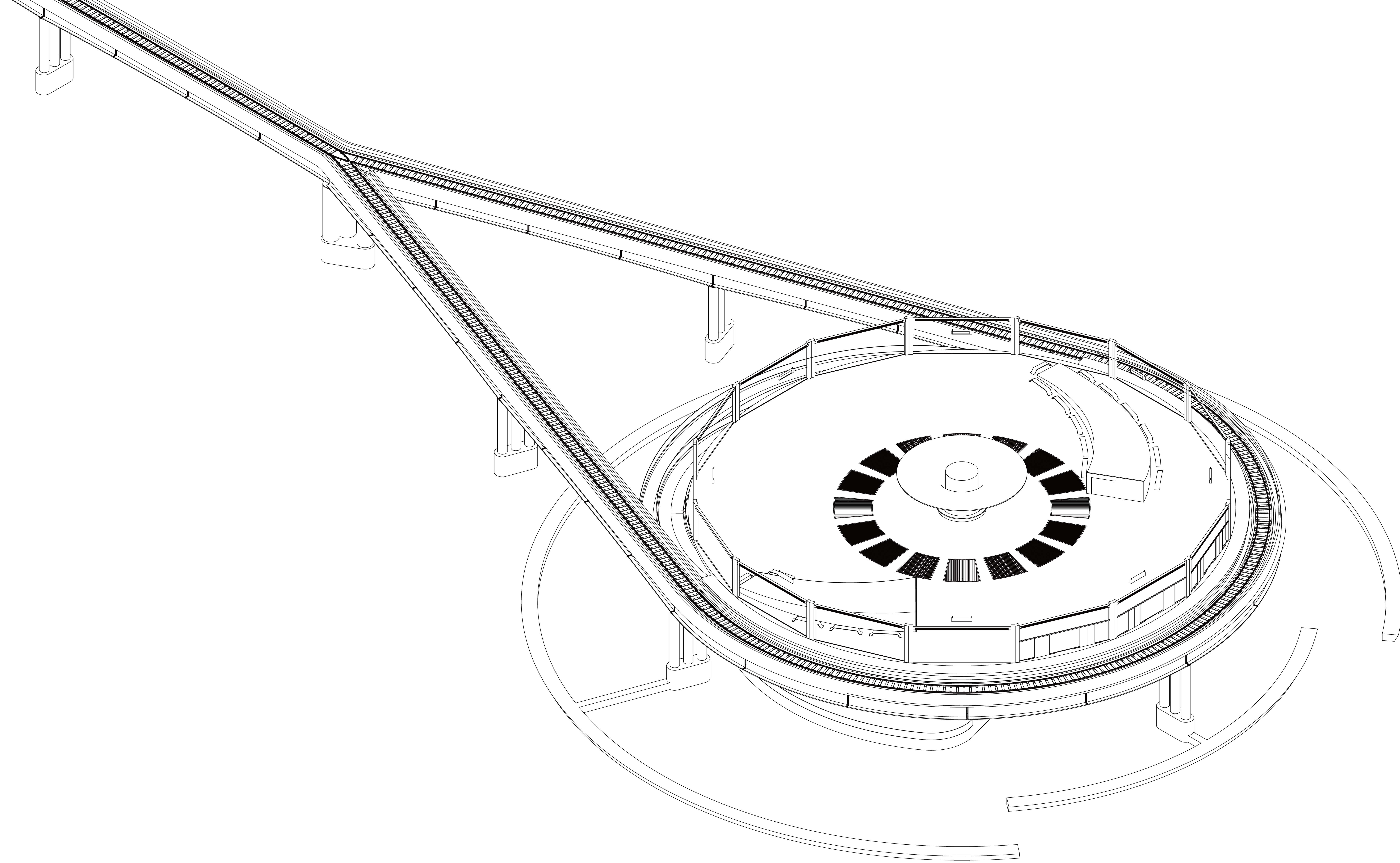

**Isometric View**

Above Water - Upper Level (Train Station)

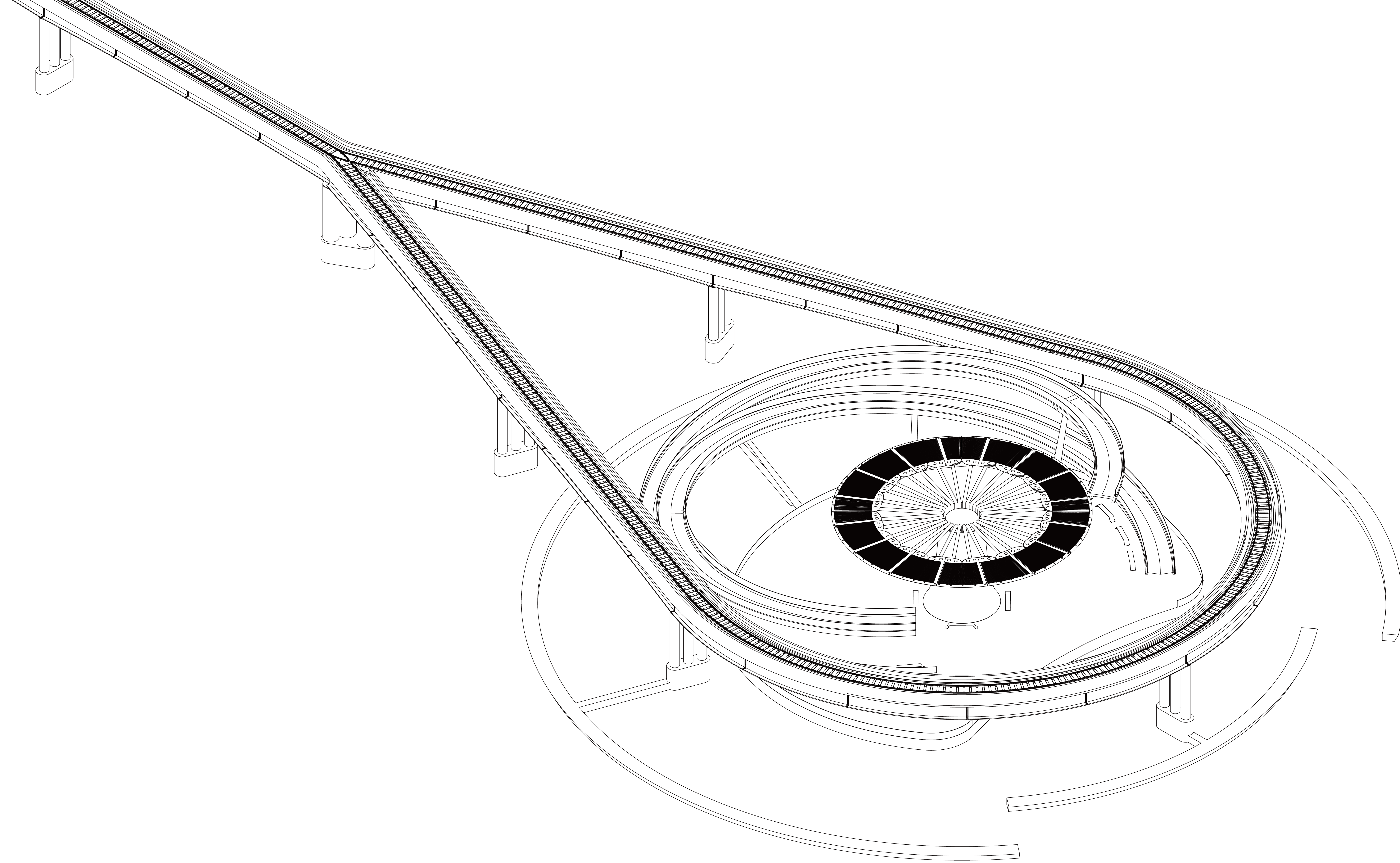

**Isometric View**  
Above Water - Under Upper Level

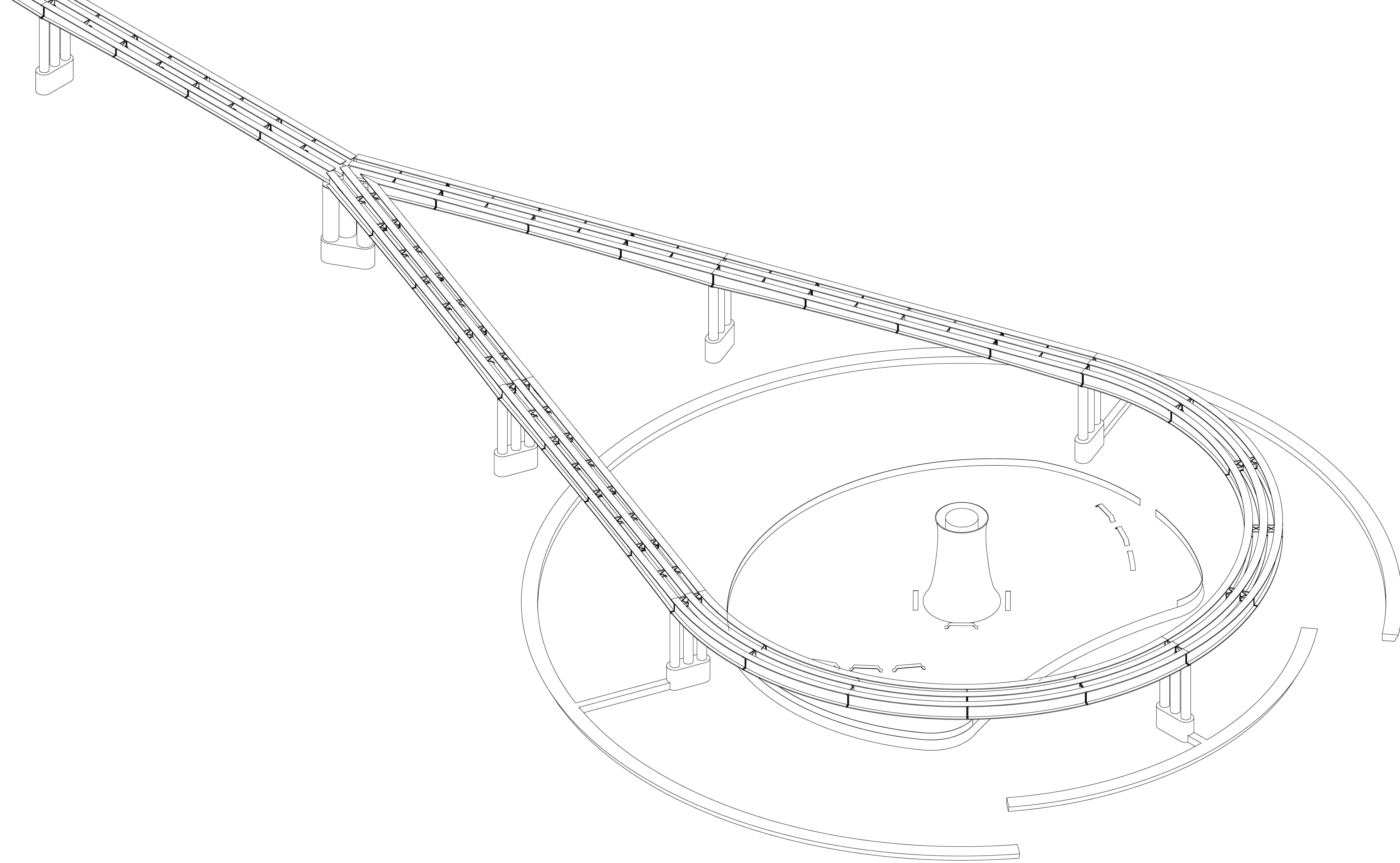

**Isometric View**

Above Water - Lower Level (Pier)

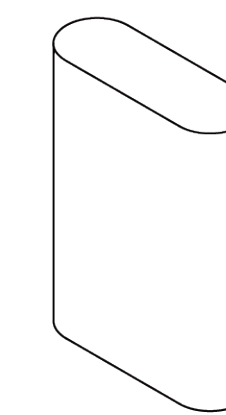
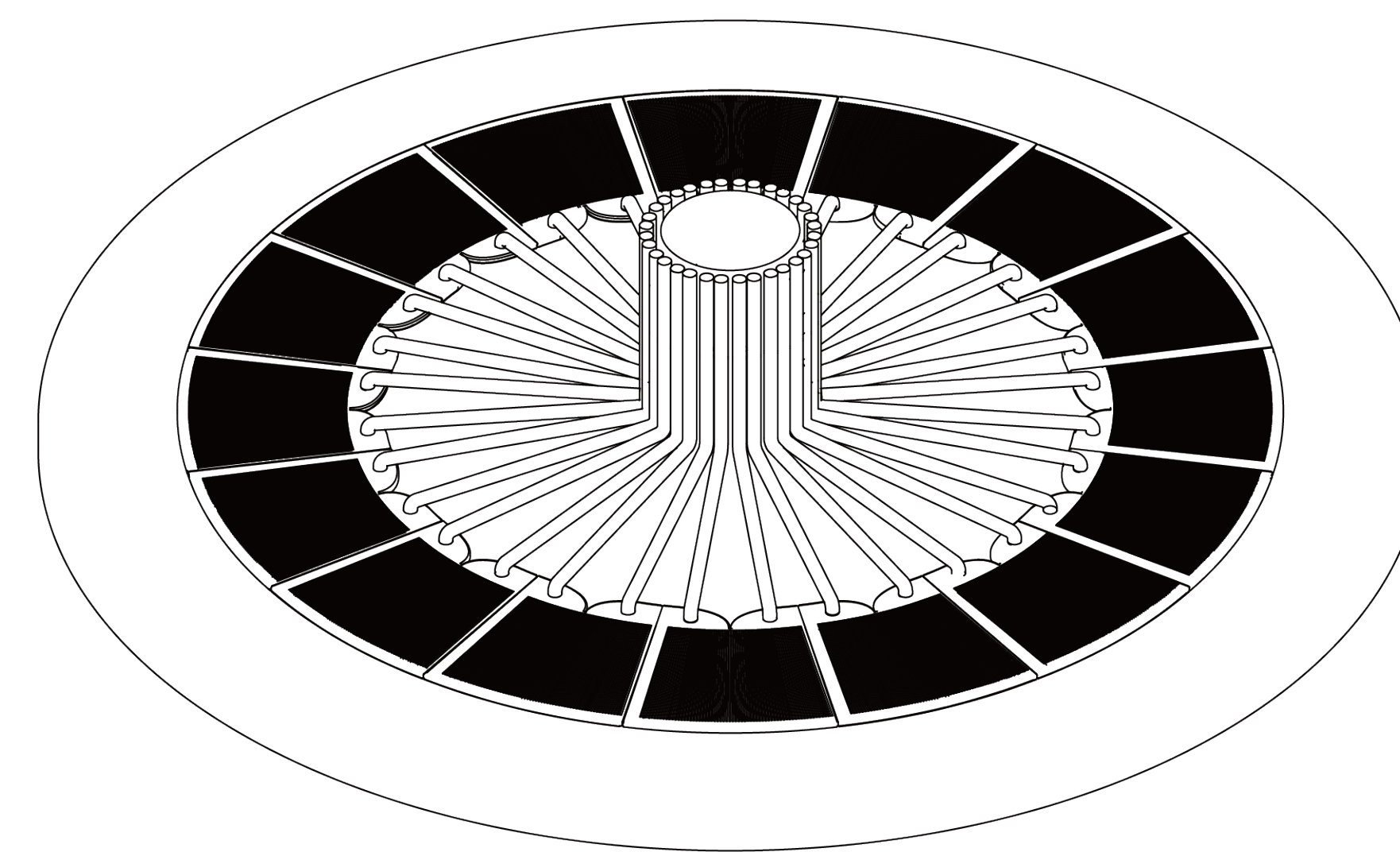
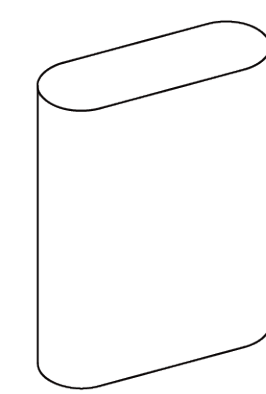
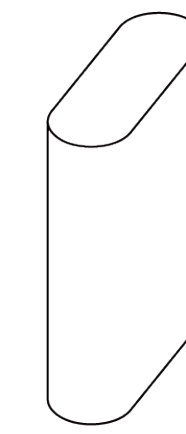
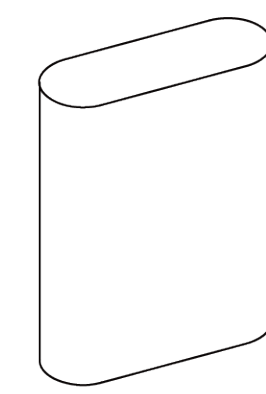
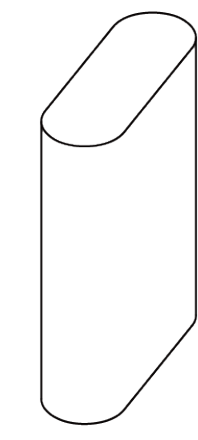
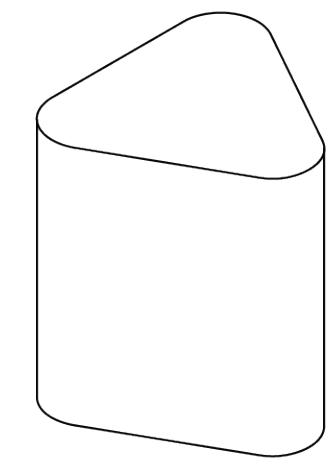
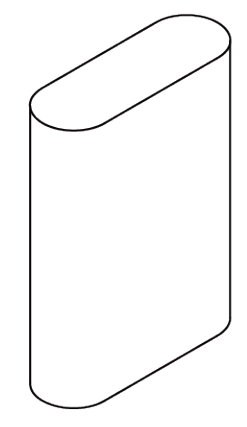

**Isometric View**  
Under Water - Foundation

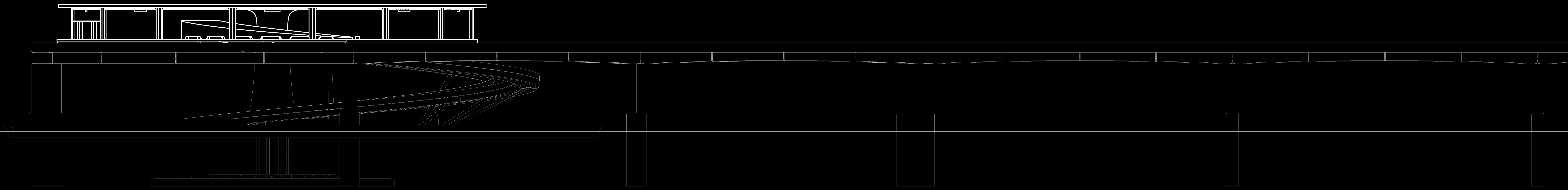

1:200

### Upper Level - Configuration

The upper level has a ring of metal protective net distributed on the floor in 16 pieces. They protect the radiator of the water cooling system installed under the upper level. This arrangement ensures that the floor of the upper level is not completely split by the protective net, leaving some connecting gaps for beams to exist to hold the structure.

One-piece French windows are distributed about the centre in 16 pieces. The three facing south are installed with platform screen doors. Each window is fixed by the side pillars which also supports the roof with the central pillar. The ventilator is located above the windows, right under the roof. Train departure boards are distributed equally with a total number of 8, ensuring that the departure information can be viewed at any spots in any angles.

Since the principle of the water cooling system requires the upper level to be completely sealed except the openings for the radiators and the ventilators acting as air ejectors, the entrances of the helix ramps are covered with acrylic structures each with an automatic door to seal the space when the entrances are not in use. Seating areas are distributed around the acrylic structures and the central pillar.

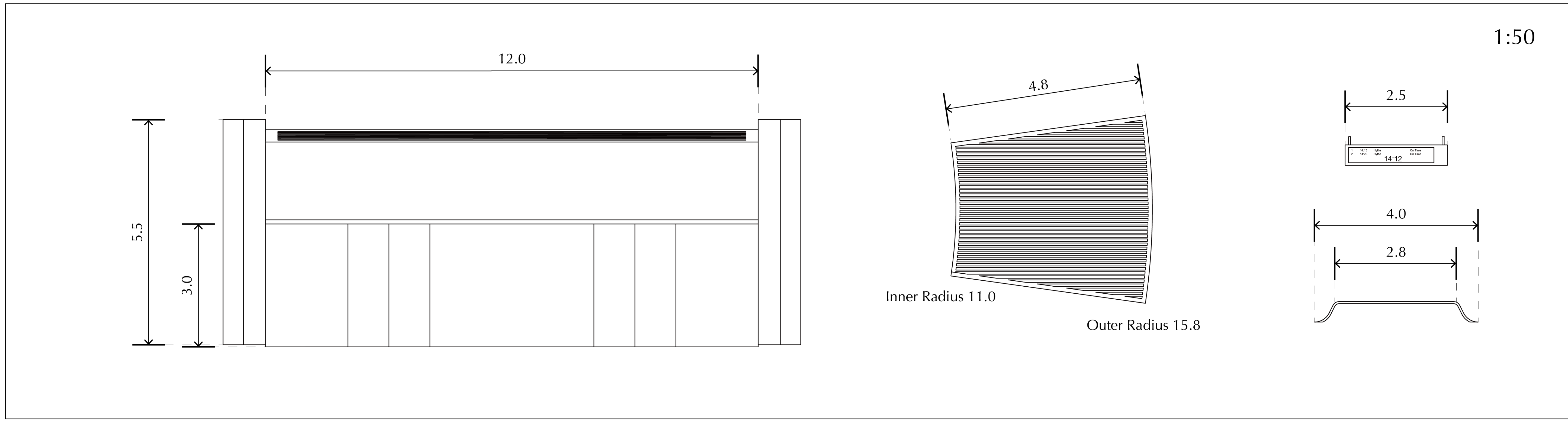
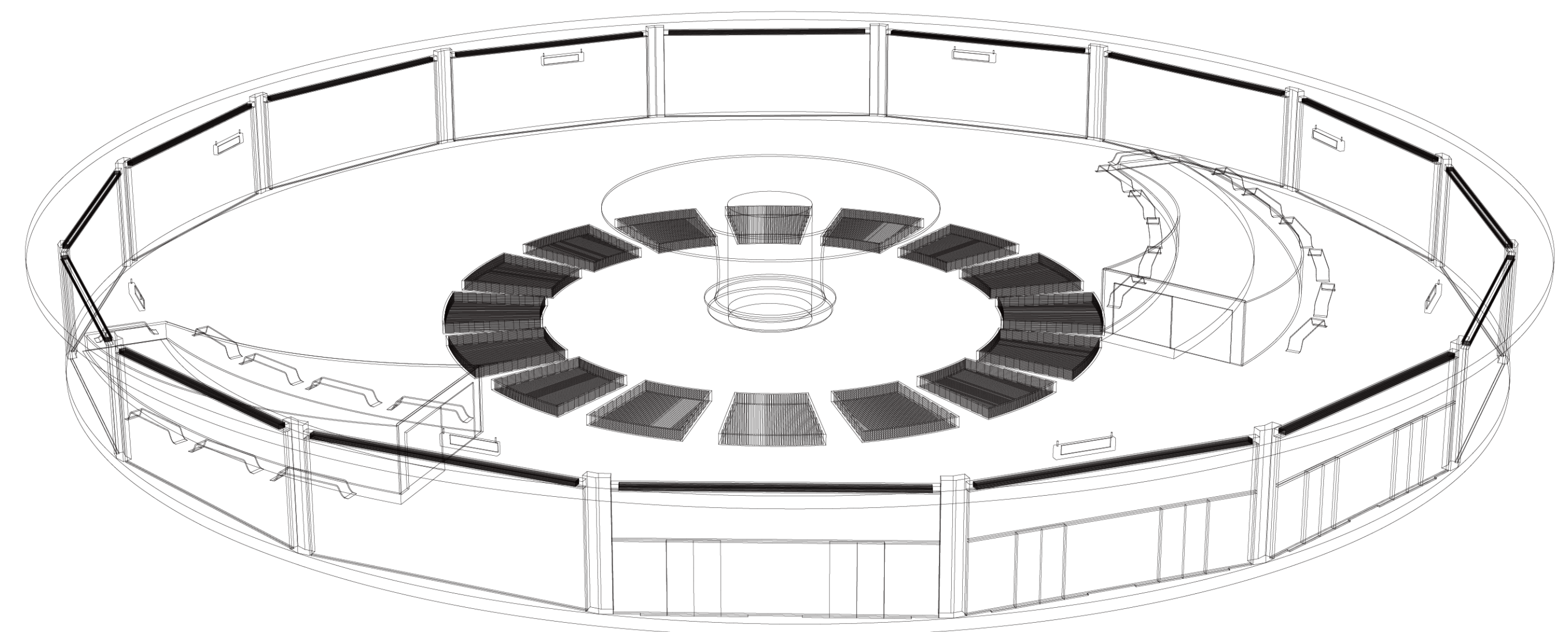
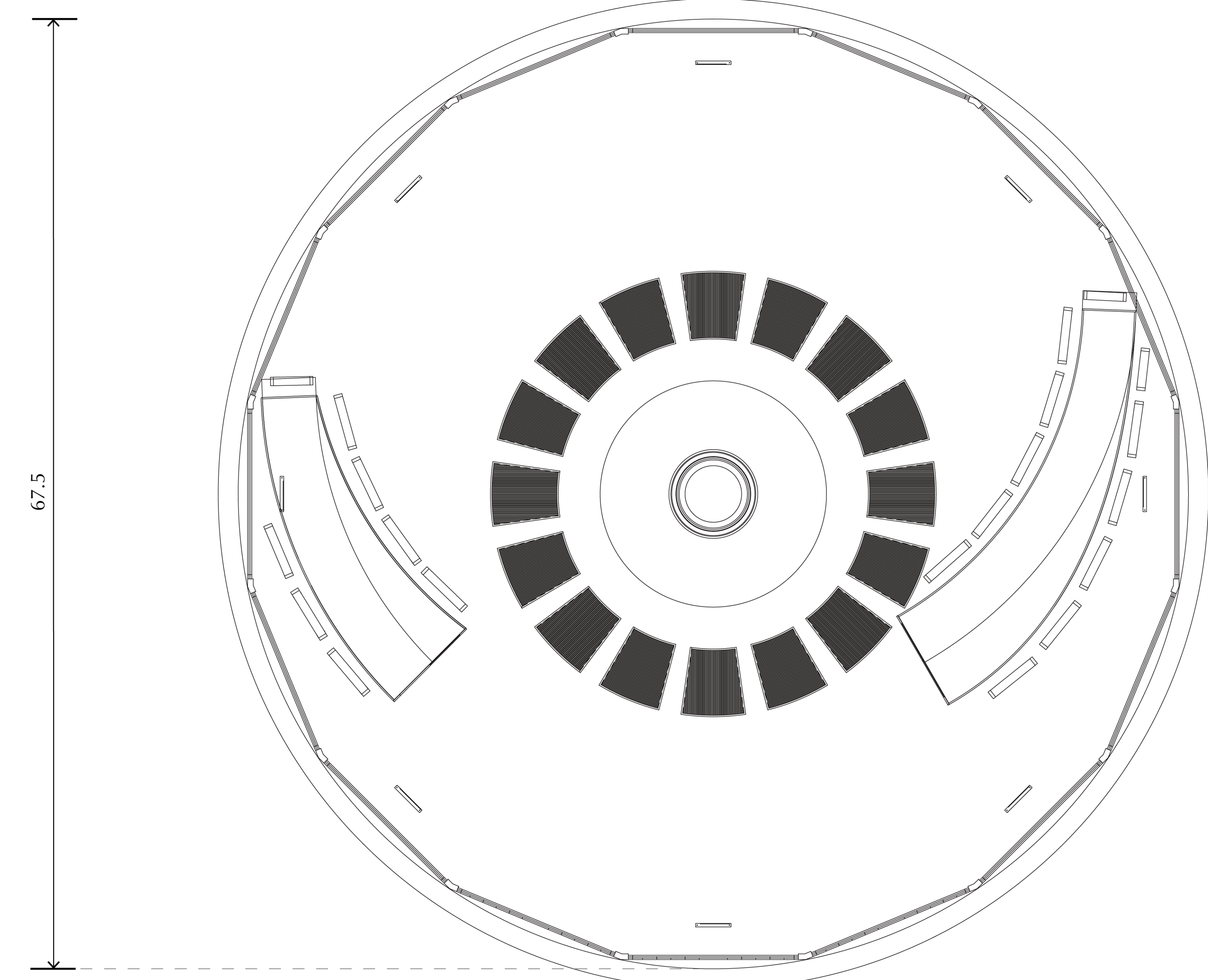
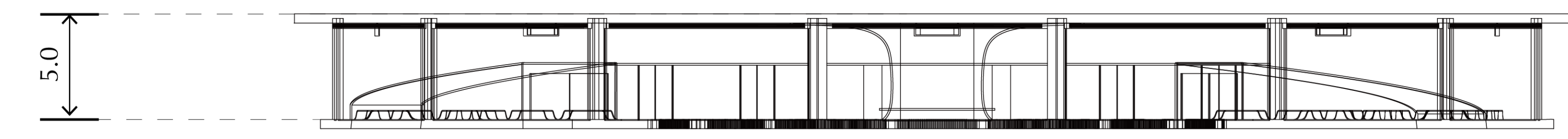

1:200

## Upper Level - Air Flow

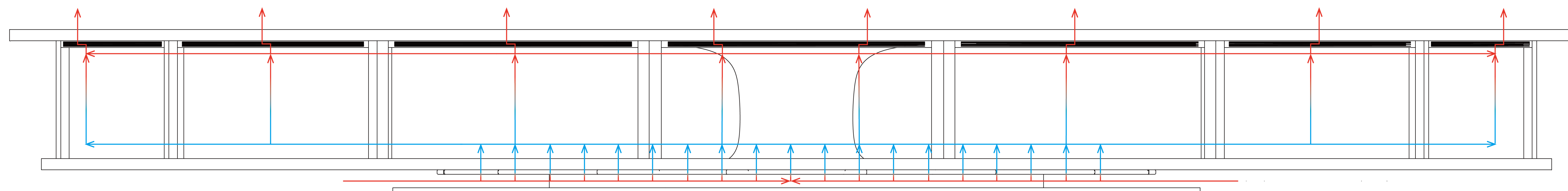

The ventilators located right under the roof, eject out inside air, which decreases inside air pressure. This forces the outside air to be pulled inside via the only permanent opening of the upper level located on the floor. Right under the openings are the upper radiators of the water cooling system. Outside air goes through the radiator to be cooled via the radiators and through the protective nets to enter the upper level, forming a ventilation cycle. Due to convection, warmer air would rise to the top and get ejected first.

As the roof of the train station is fully exposed to solar radiation, the water cooling system is thought to work as a cooler for majority of the time. The water cooling system is cooled by seawater. The water temperature across the year shows that it varies in a range of 8 to 18 degree Celsius, ensuring a great cooling ability across the entire year. In the extreme the temperature has dropped into a level where the water cooling system is no longer benefiting, simply turn off the ventilators to greatly lower the air exchange rate, even without the ventilators, convection would still cause the minimum ventilation to occur.

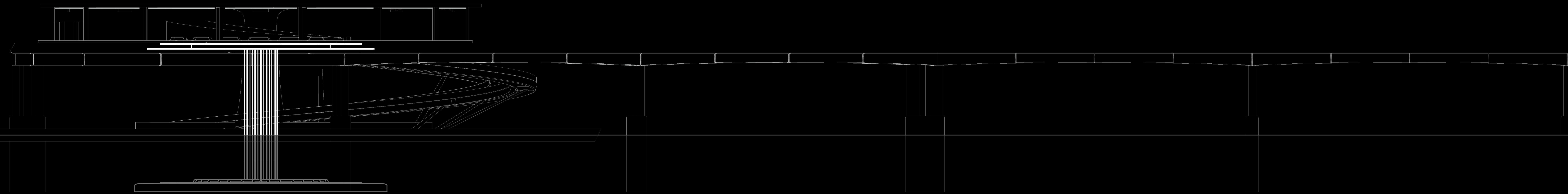

1:200

### Water Cooling System

A diagram showing the water flow within an upper radiator is shown. Cold water cools the air and gains the heat from the air and become warm water. Warm water returns to the lower radiators to be cooled again, forming a cycle.

Arrays of the upper and the lower radiators are the same to avoid bend for the tubes to ensure that the distance in between the upper and lower radiators is the minimum. The pump is set within the foundation

A gap of 0.6 meters was reserved in between the radiator and the roof of the pier, to allow outside air to be pulled into the upper level due to pressure difference. A barrier is set under the radiators to ensure all air goes through the radiator.

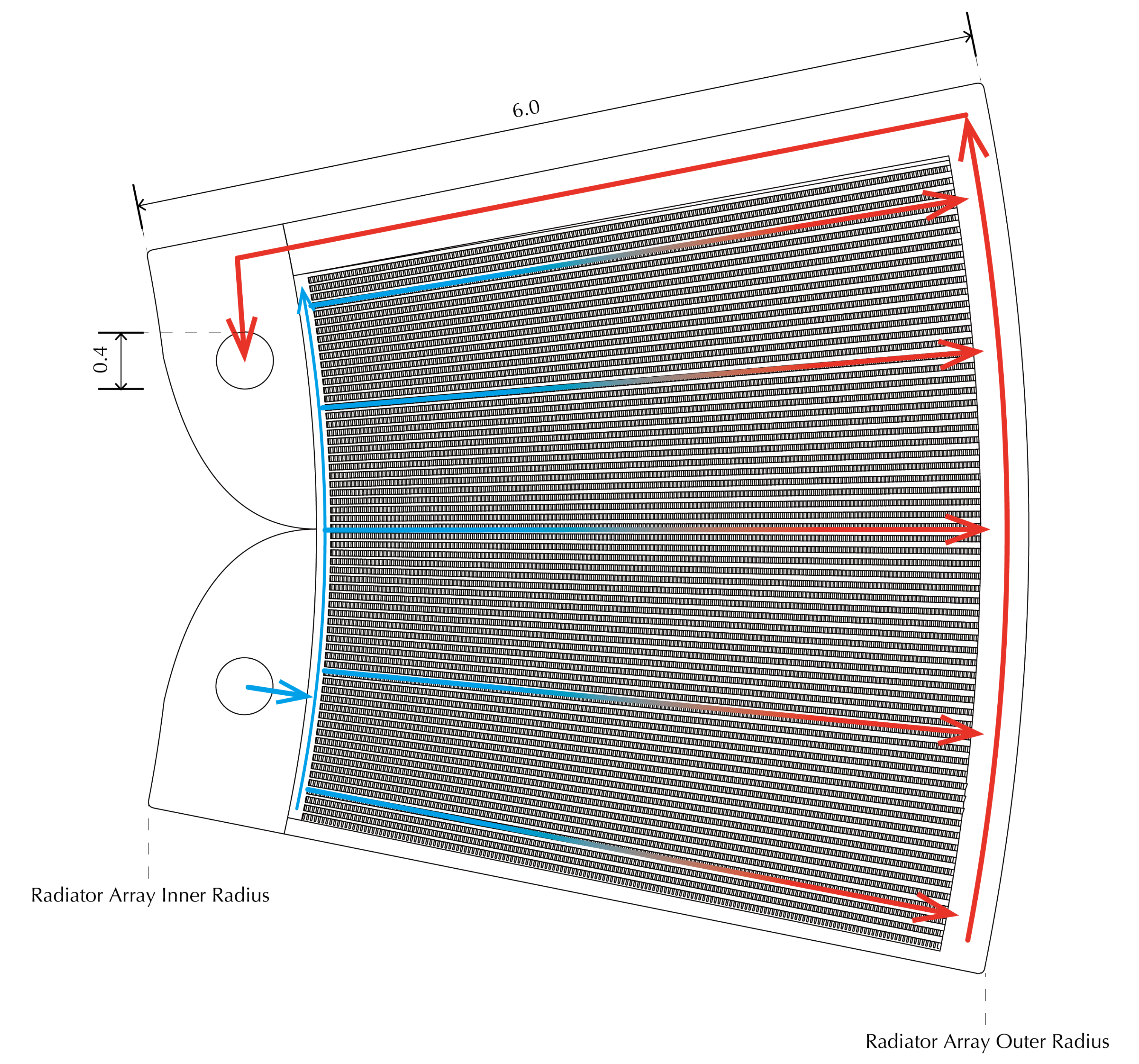
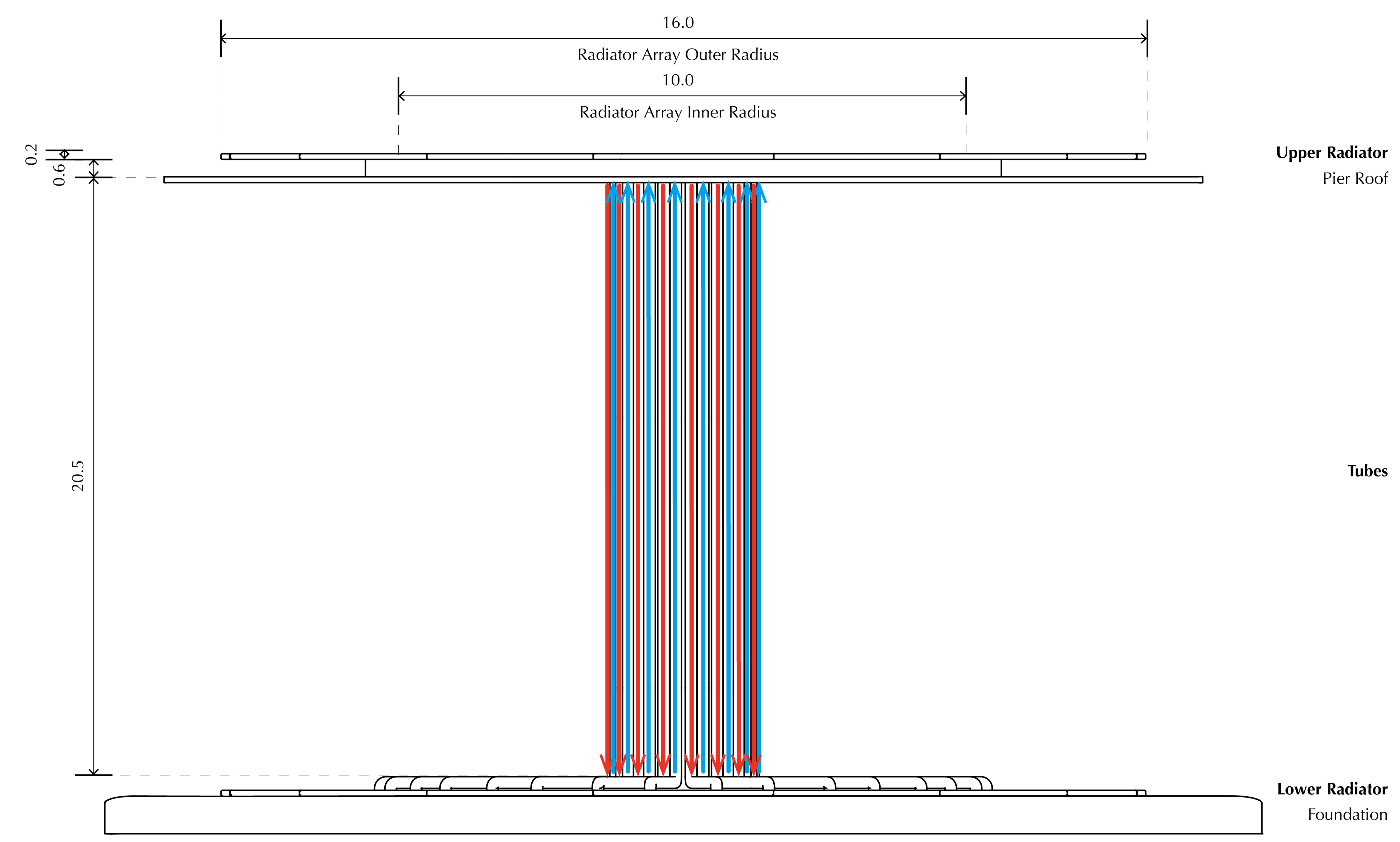

Not to Scale

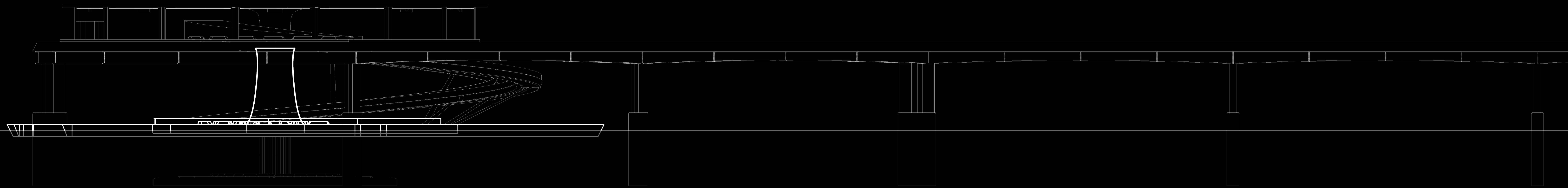

1:200

The pier has a 'chopped' circular shape, where a circle with a radius of 30 meters is split by a circle with a radius of 60 meters moved due south for 77 meters. This design offers smoother entrance, exiting, docking and boarding experience. Except the docking area, the lower level is bordered by glass fence similar to the helix ramps.

The harbour entrance surrounds the lower level to protect it against to waves. A 75-degree sector due south cuts the 60-meter-radius circular axis, creating two 10-meter gap to allow boats to enter and exit.

The middle pillar is made out of acrylic board to be transparent, allowing the biggest feature: water cooling system's water tubes to be shown to the passengers. The support of the structure is on the central pillar, surrounded by the water tubs. Seating areas are distributed around the entrances of the helix ramps and the middle pillar similar to the upper level.

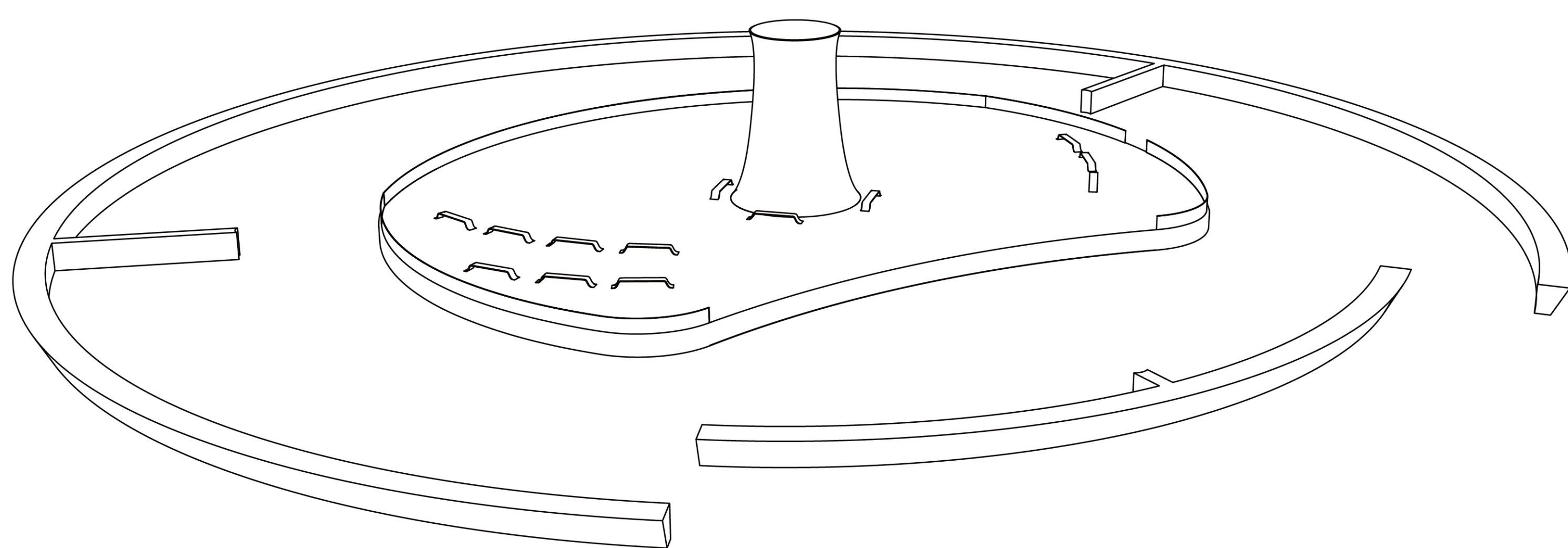

Lower Level

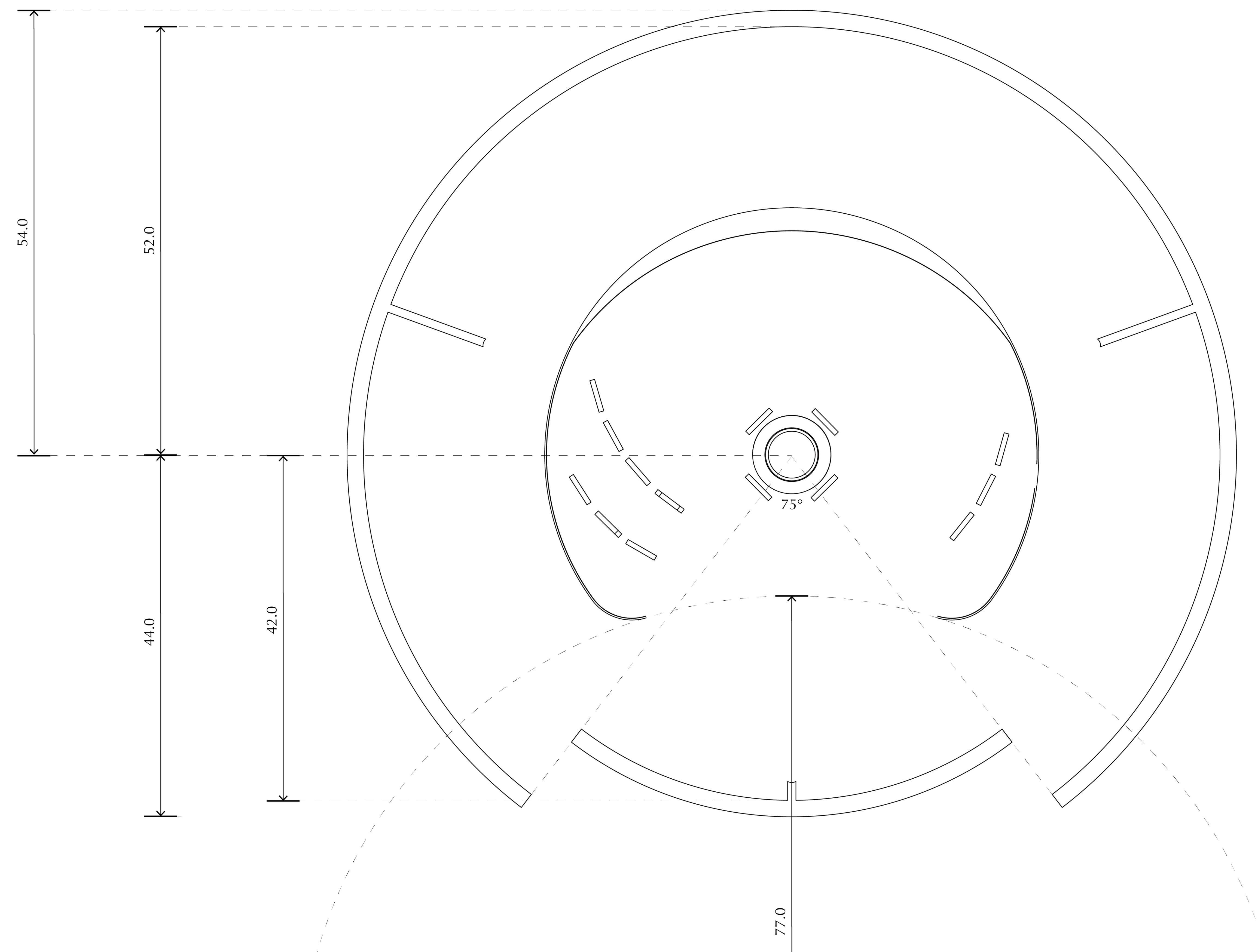

1:250

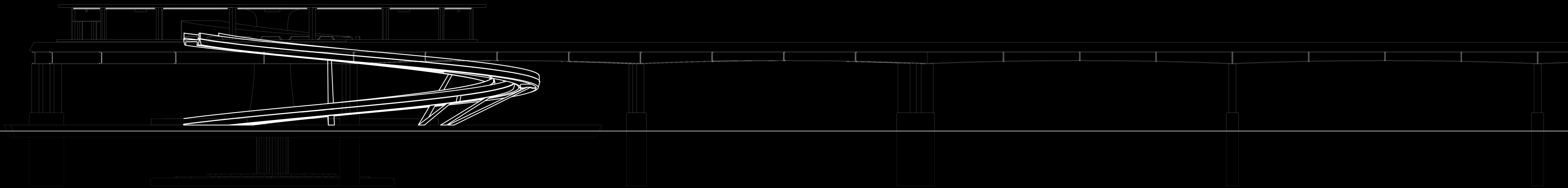

1:200

## Helix Ramps

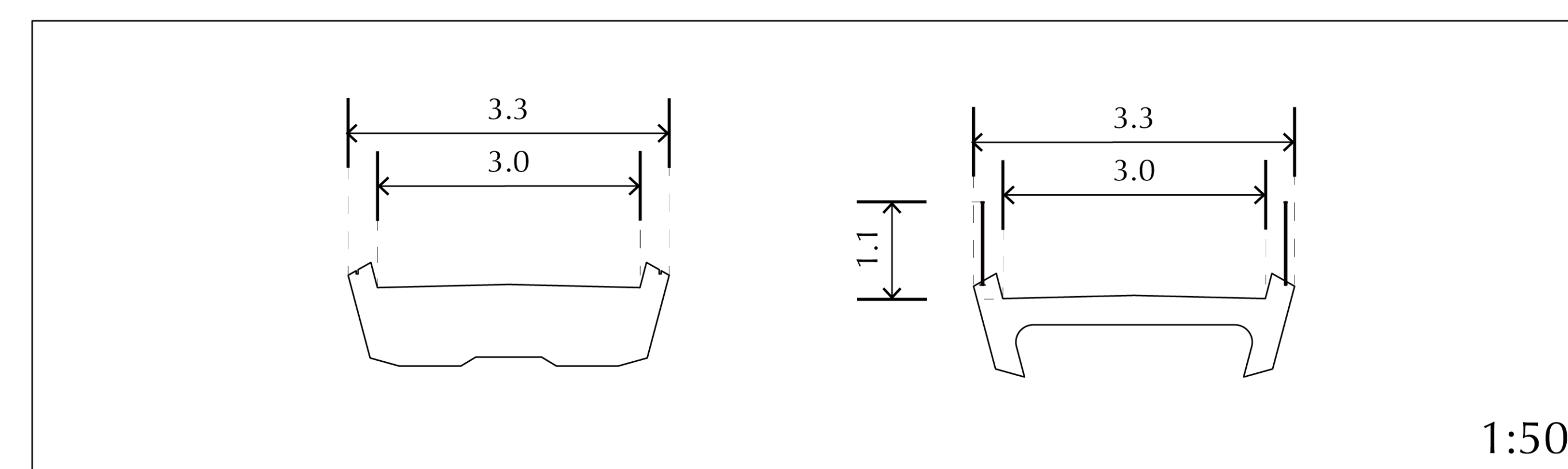
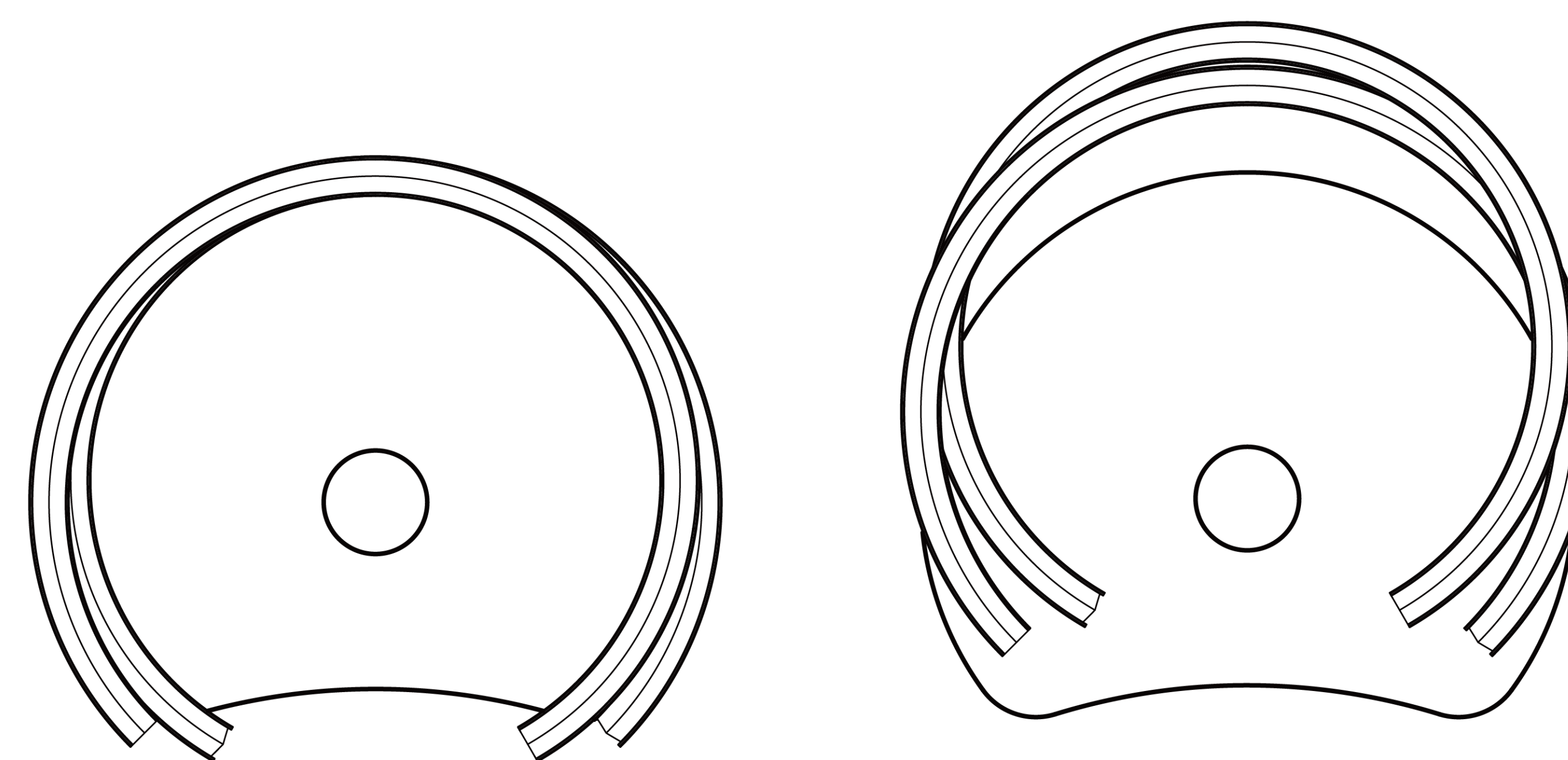
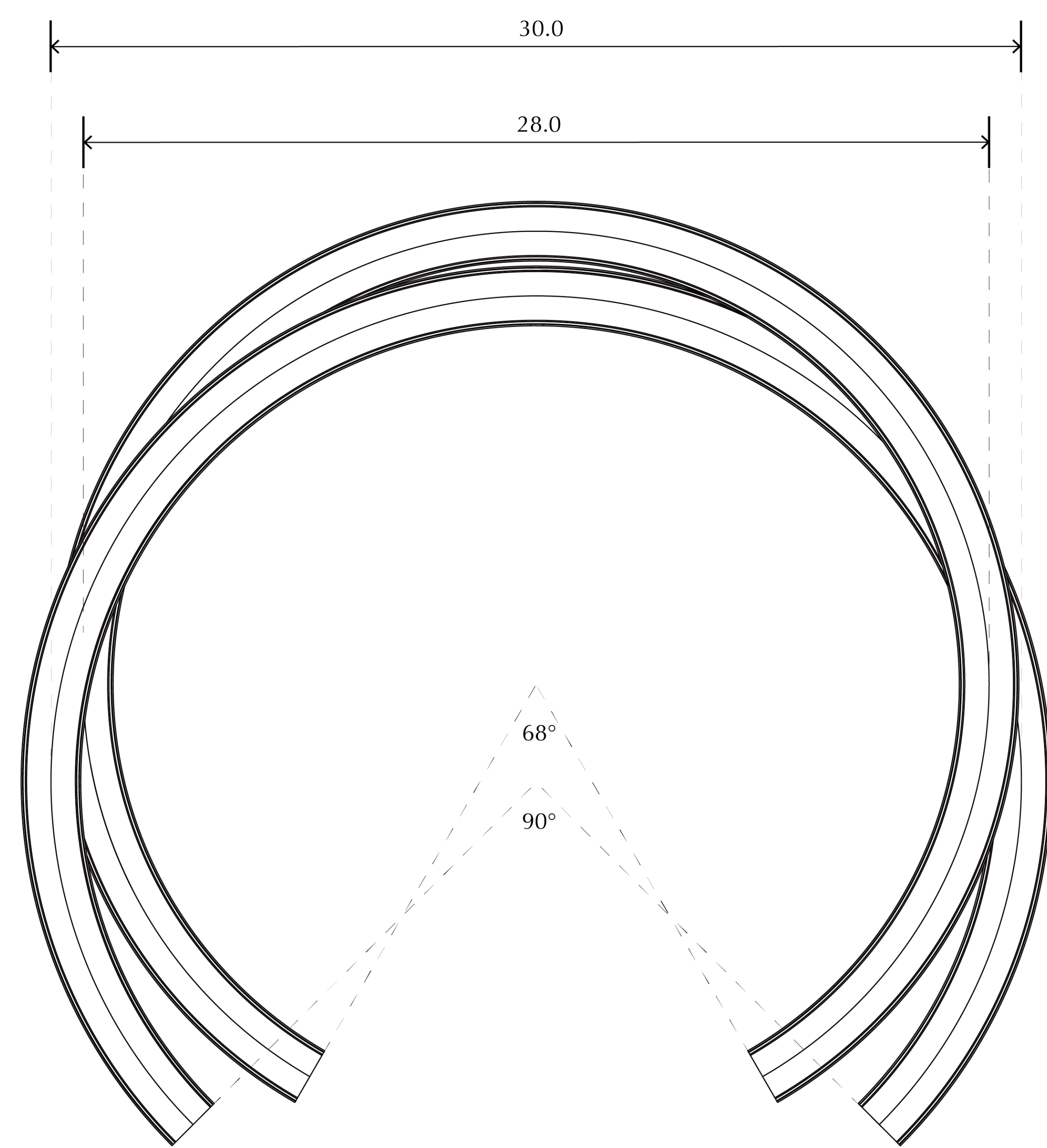

Helix ramps were designed in a way that they do not intersect. The lengths of both ramps were also limited to be greater than 140 meters, as the height between the upper level and the lower level is 14 meters and the recommended lift ratio for walking ramp is in between 1:10 and 1:12. The ramps were also not to be above the docking area, which means the turn of each helix shall not exceed 0.7.

This design challenge was solved by creating a 0.81-turn helix with a radius of 28 meters, and moved due north by 12 meters to be hanged above the sea to avoid the docking area. Similar for the other ramp, a 0.75-turn helix with a radius of 30 meters was moved due north by 8 meters to be also hanged above the sea to avoid the docking area. This arrangement also brings an interesting phenomenon: despite with different radius, neither of these helixes completely cover one another, unlike regular double helix designs.

Not to Scale

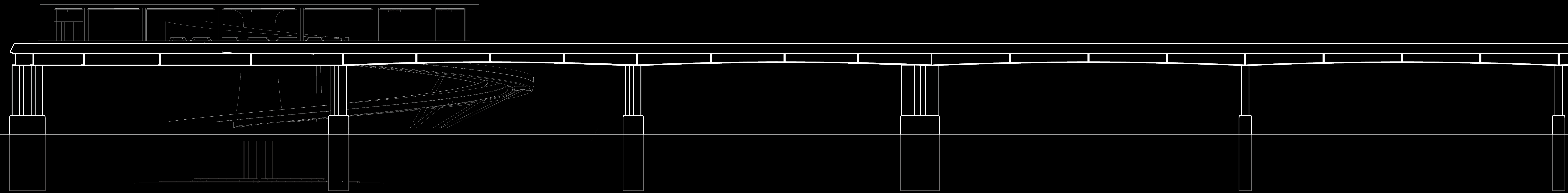

1:200

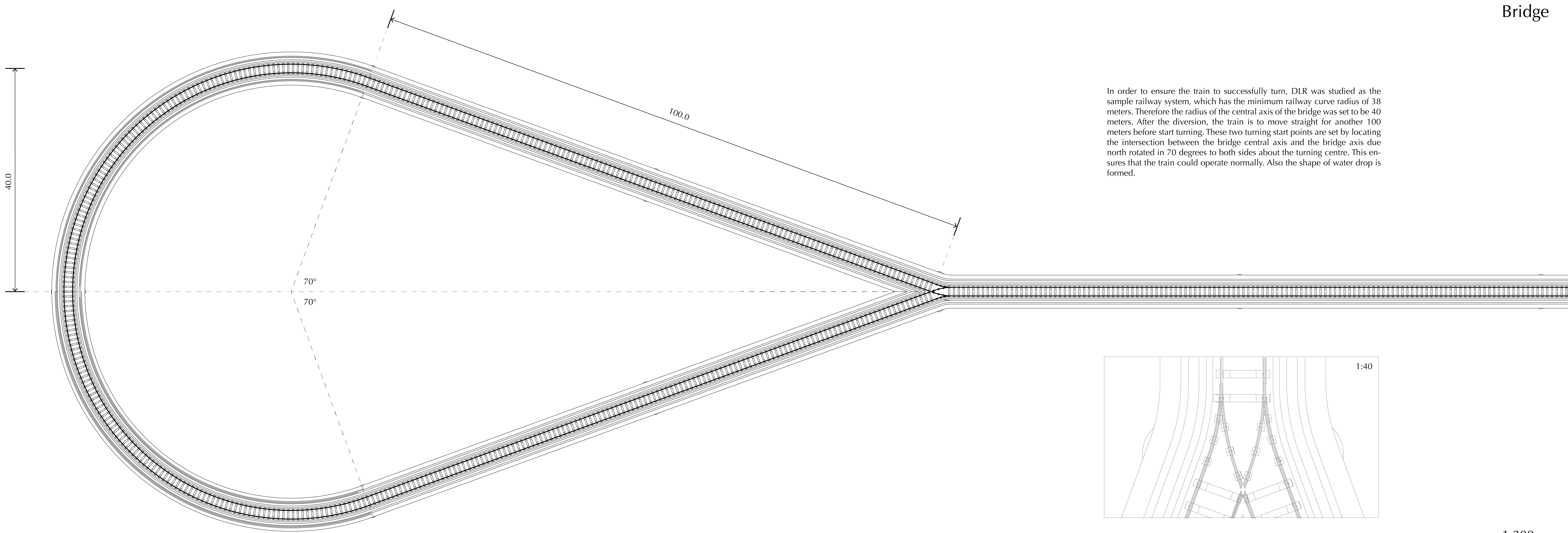

In order to ensure the train to successfully turn, DLR was studied as the sample railway system, which has the minimum railway curve radius of 38 meters. Therefore the radius of the central axis of the bridge was set to be 40 meters. After the diversion, the train is to move straight for another 100 meters before start turning. These two turning start points are set by locating the intersection between the bridge central axis and the bridge axis due north rotated in 70 degrees to both sides about the turning centre. This ensures that the train could operate normally. Also the shape of water drop is formed.

Bridge

1:200

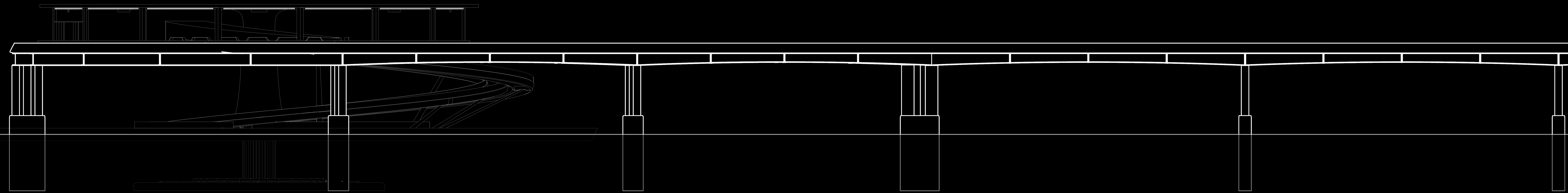

1:200

Bridge

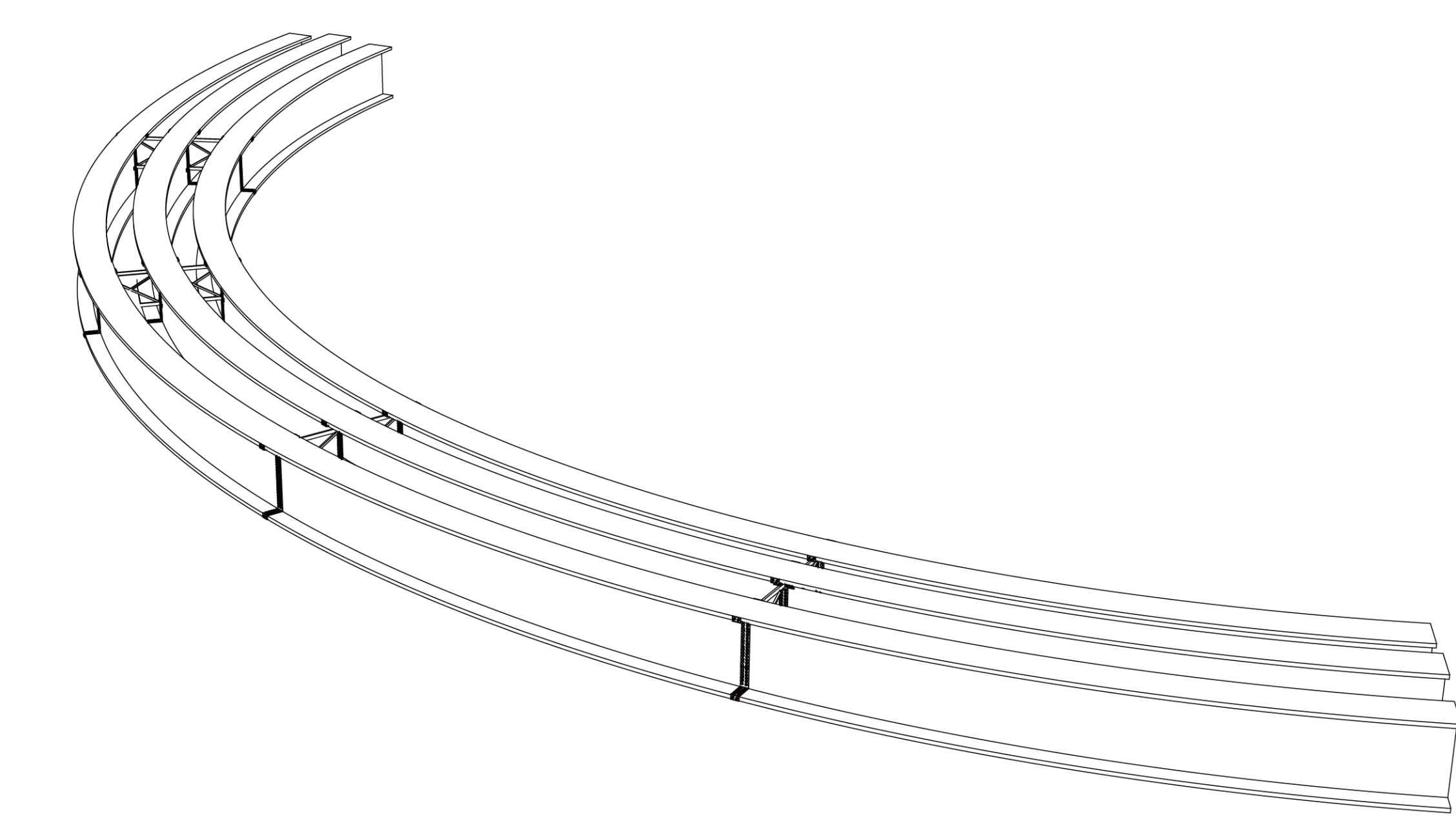
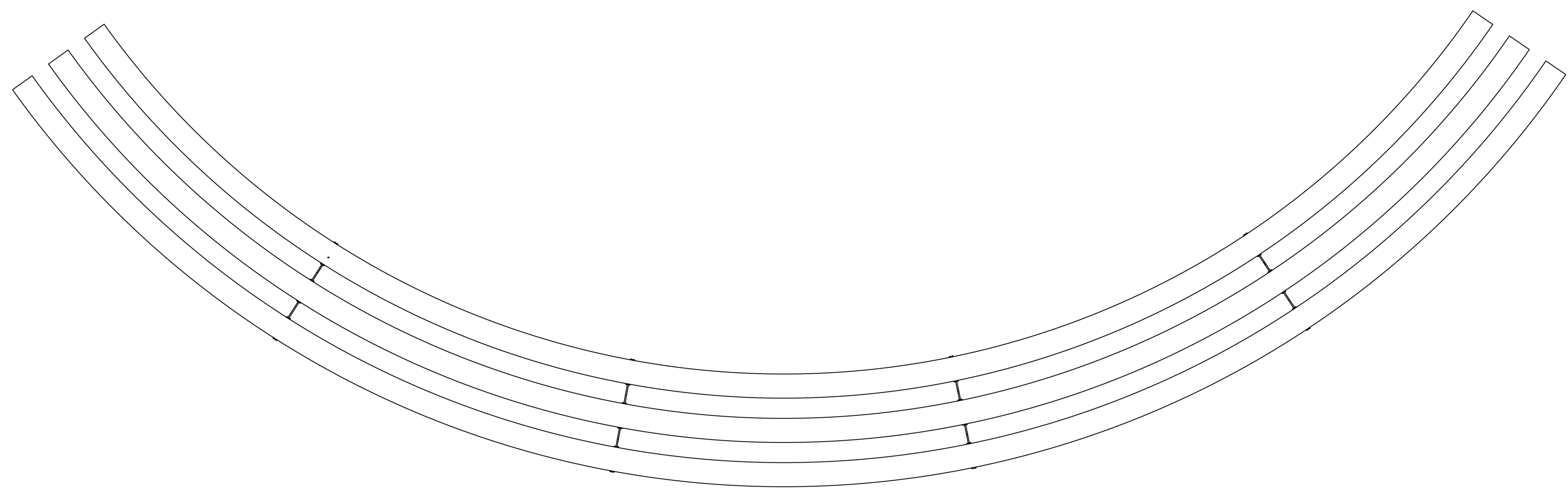
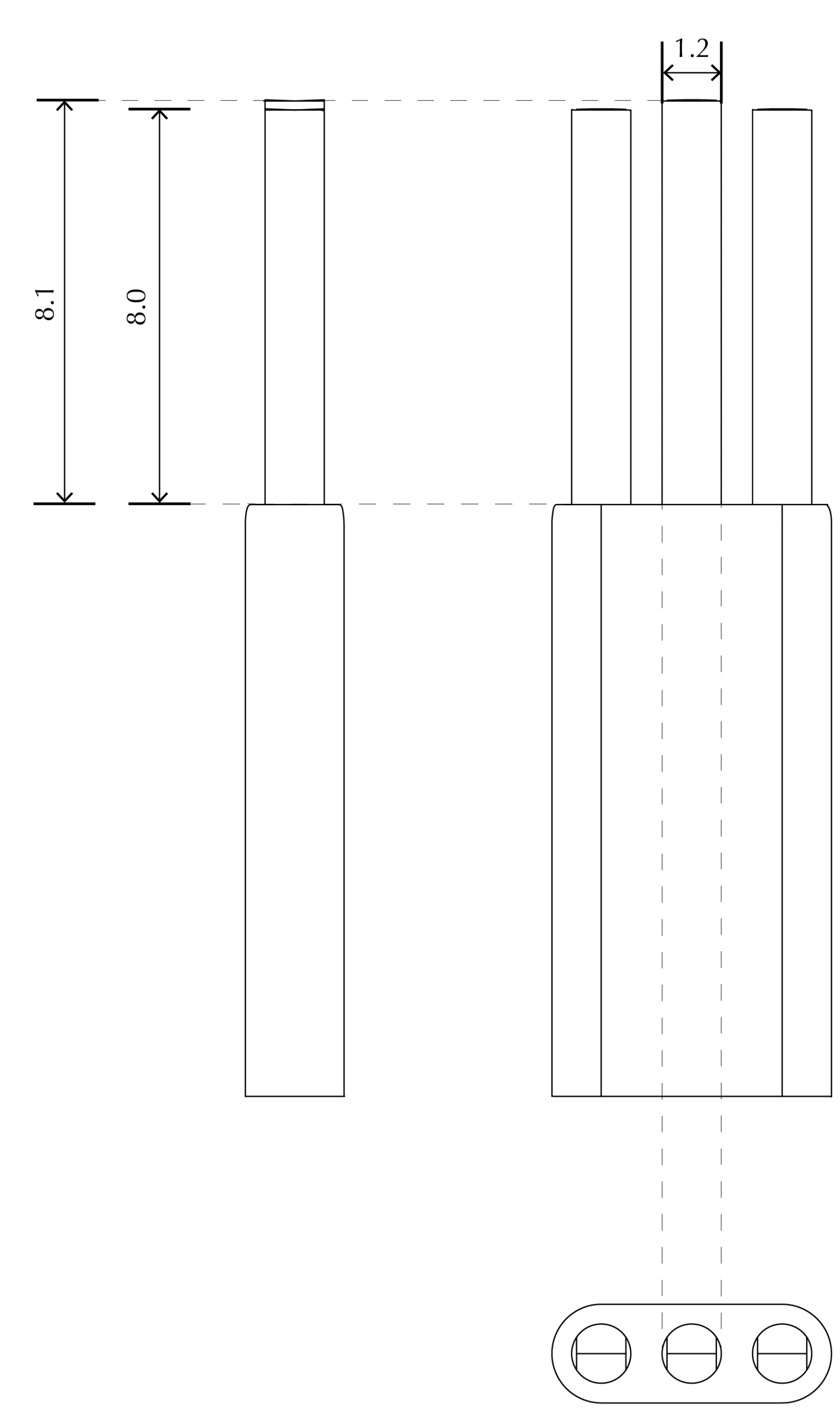
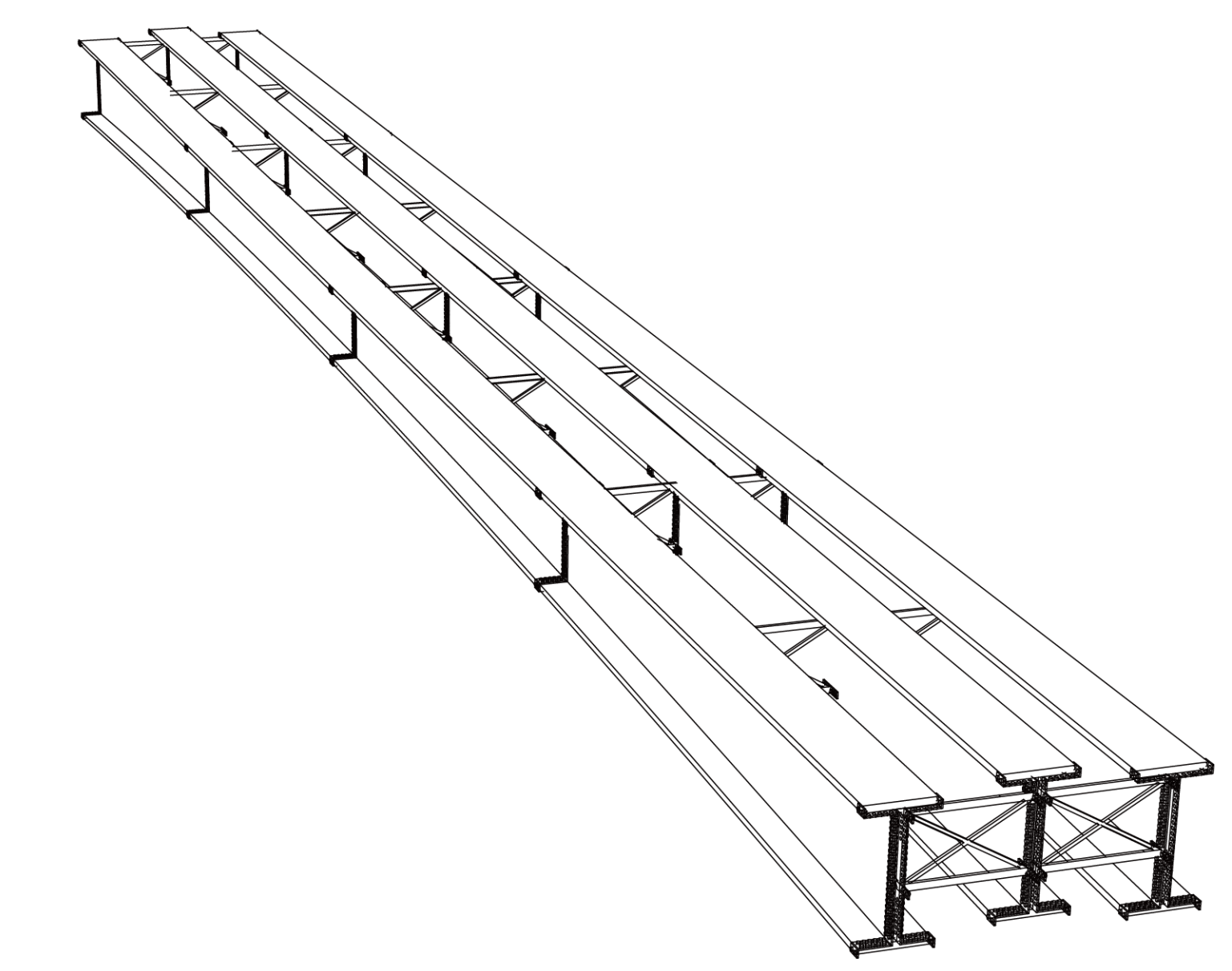
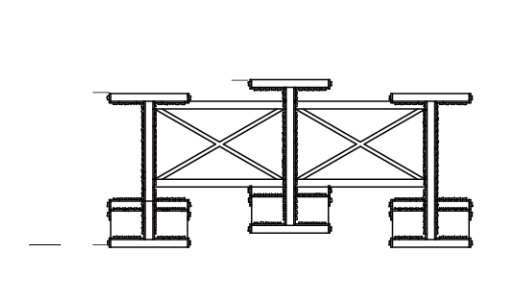
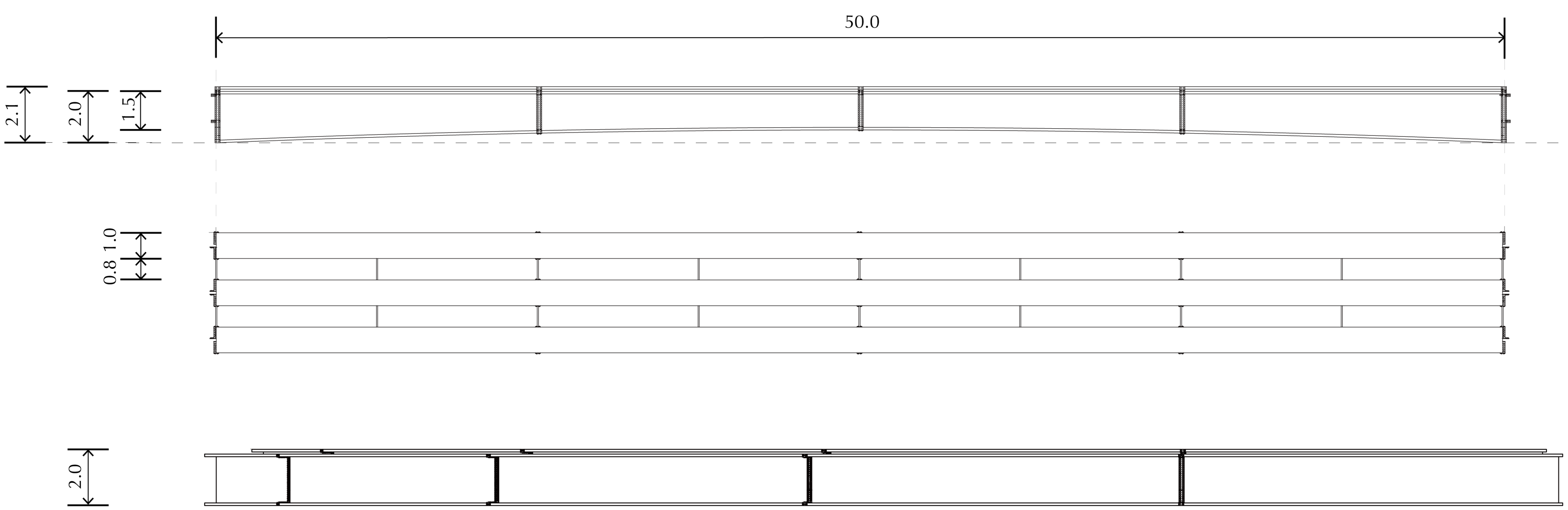

Not to Scale

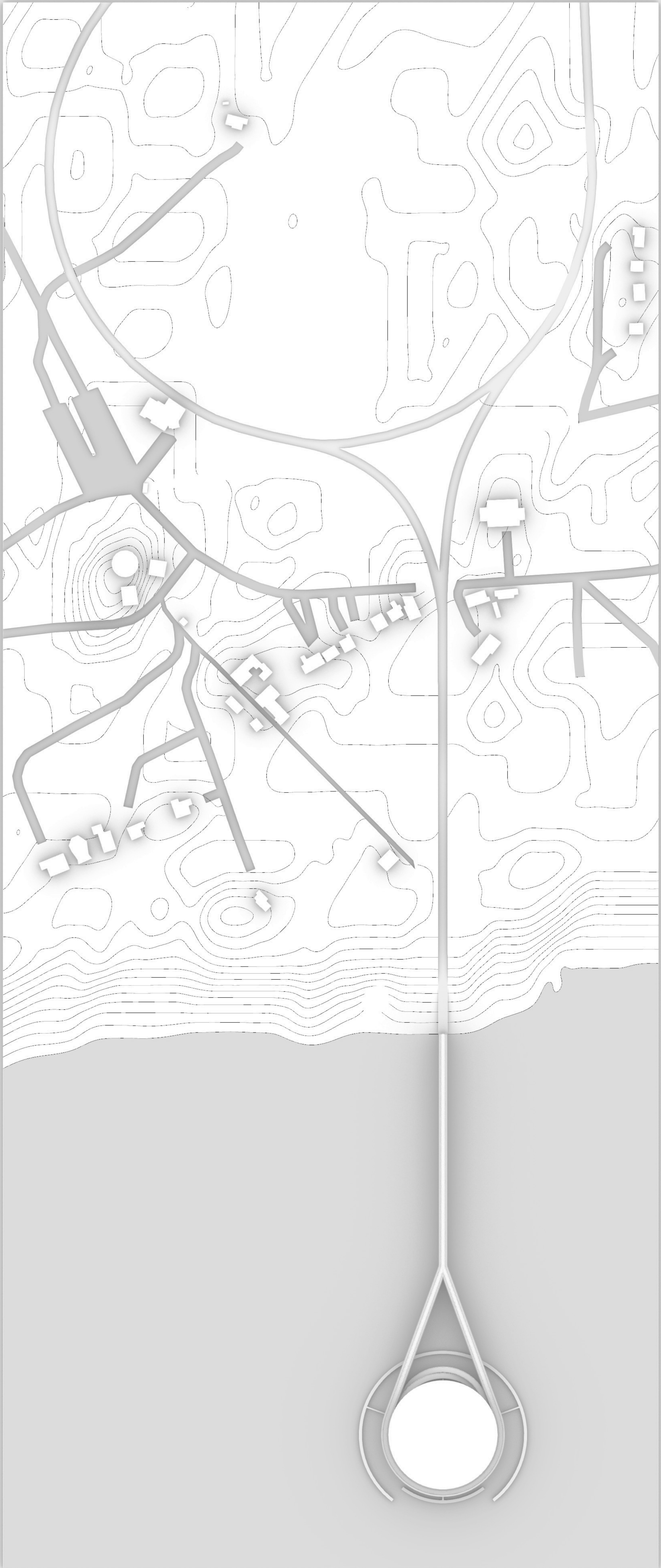

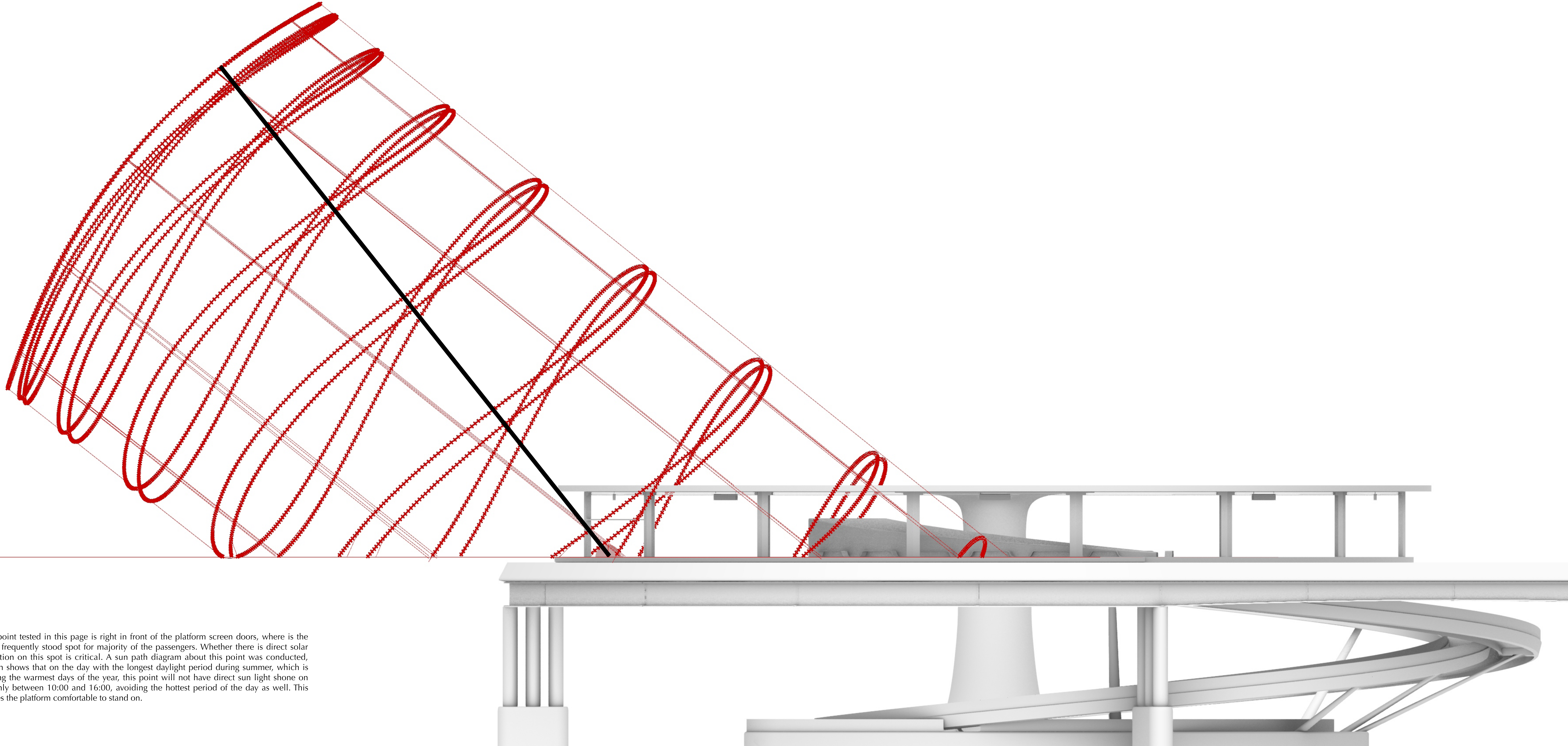

The point tested in this page is right in front of the platform screen doors, where is the most frequently stood spot for majority of the passengers. Whether there is direct solar radiation on this spot is critical. A sun path diagram about this point was conducted, which shows that on the day with the longest daylight period during summer, which is among the warmest days of the year, this point will not have direct sun light shone on roughly between 10:00 and 16:00, avoiding the hottest period of the day as well. This makes the platform comfortable to stand on.

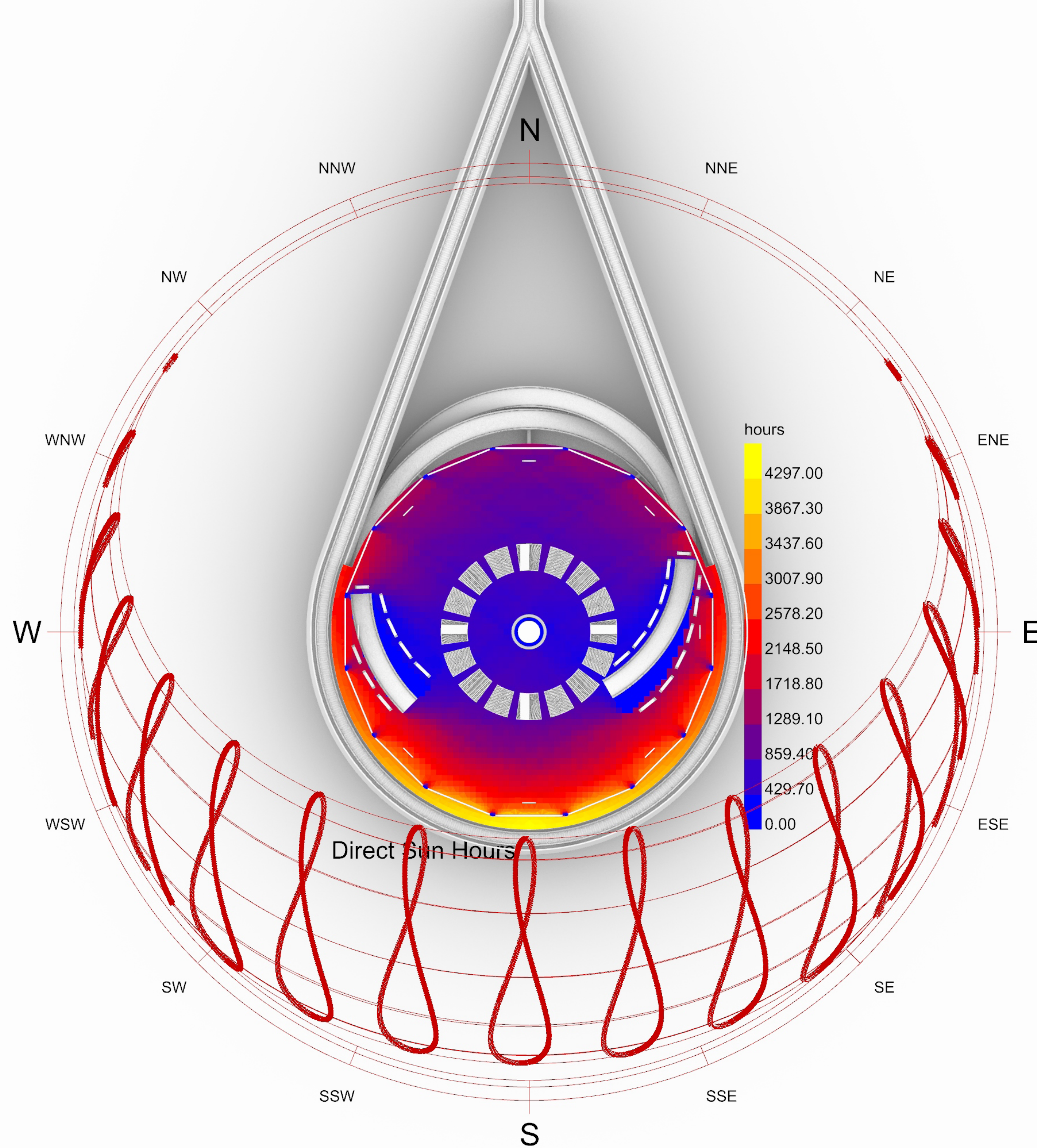

Direct sun hours on the train station, the upper level were visualised. The northern and the central parts of this level, which were designed as waiting and sight-viewing areas, have little direct sunlight, which meets the concept of avoiding solar radiation in the resting and leisure areas, especially the central area where the water cooling system locates. The only sun hours on these areas are in evening or morning that gain less solar radiation. The central area barely has any sunlight further due to the block of the helix ramps. The seatings surrounding the helix ramp entrances offer a choice of either facing the outside to be shone by the sunlight, or the seatings facing inside to avoid sunlight. The platform area has the largest sun hours due to its direction. However, the number is downed into an acceptable level by the roof.

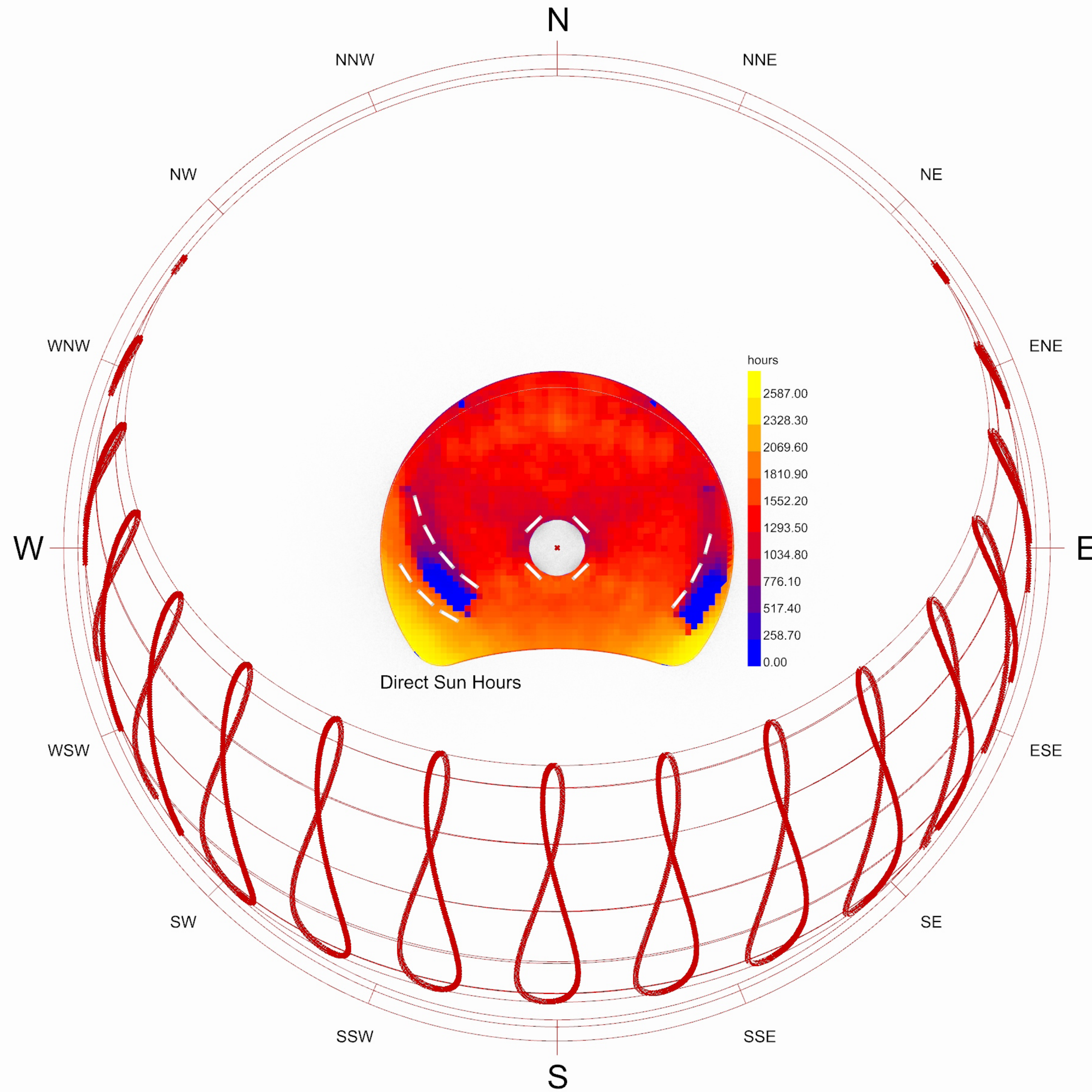

Direct sun hours on the pier, lower level were visualised. Similar to the upper level, the northern and the central parts of this level were designed to be the waiting and sight-viewing areas. These areas barely have any sunlight, which matches with the design concept. The southern part of the pier has the largest sun hours due to its facing. The seatings offer less choices as since the upper level is water cooled, the passengers were expected to tend to wait in the upper level more. Despite so, there are still a few seats facing south west provided with some sunlight. The sun hour on the boarding area, the south edge of the southern area, has an acceptable level of sun hours.

