

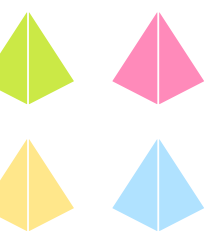

# The Drawing Machine

Unit 3

Kim, Gabs, Kate, Isaac & Josh



# Inspiration



JOSEPH GRIFFITHS  
2009

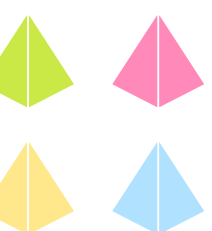



ESKE REX

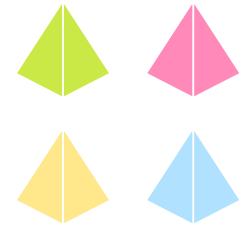

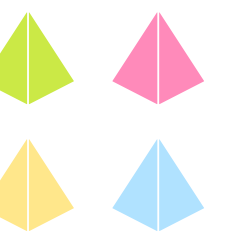

# SWINGING PENDULUMS

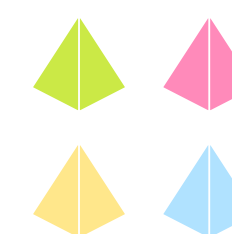
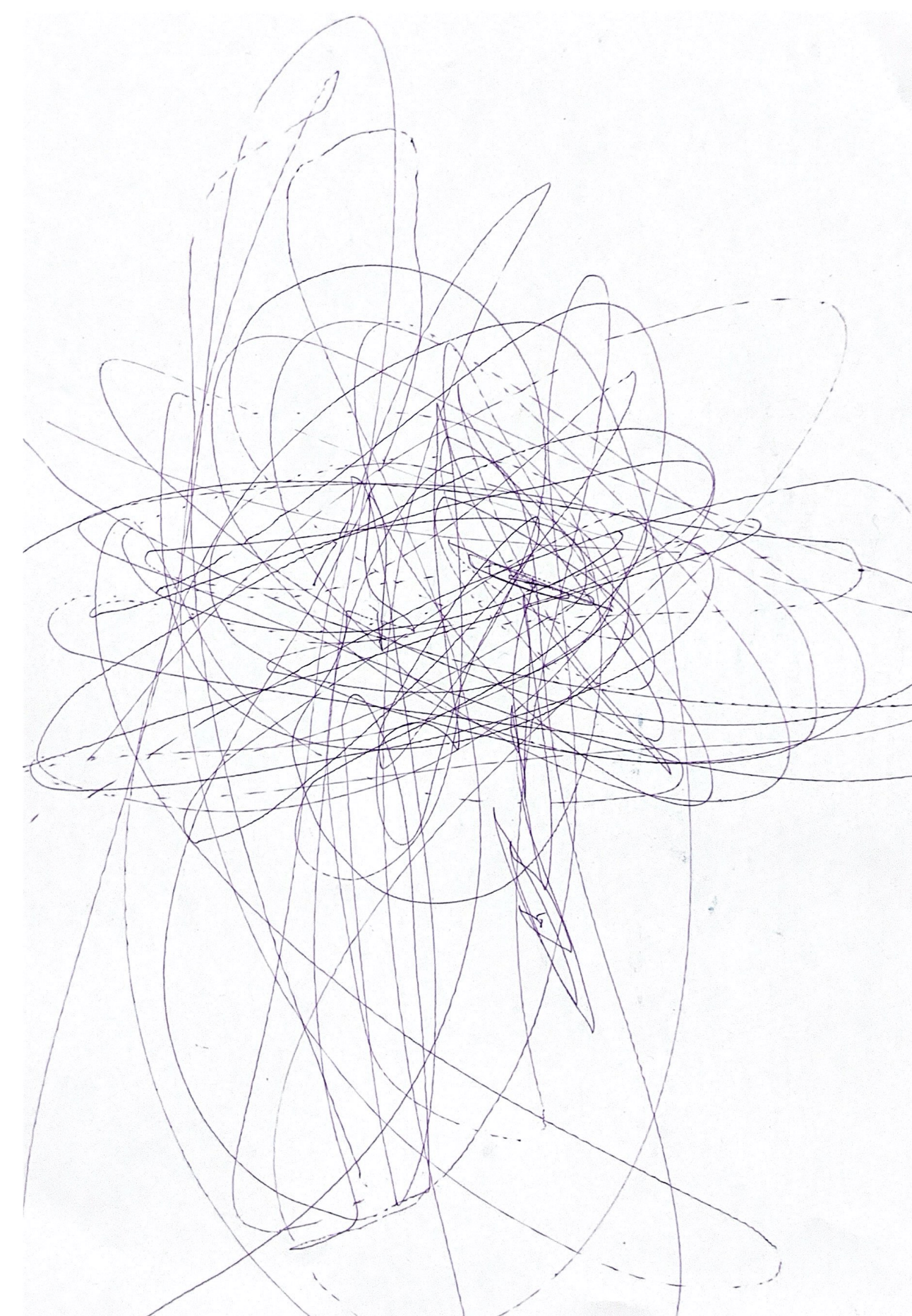
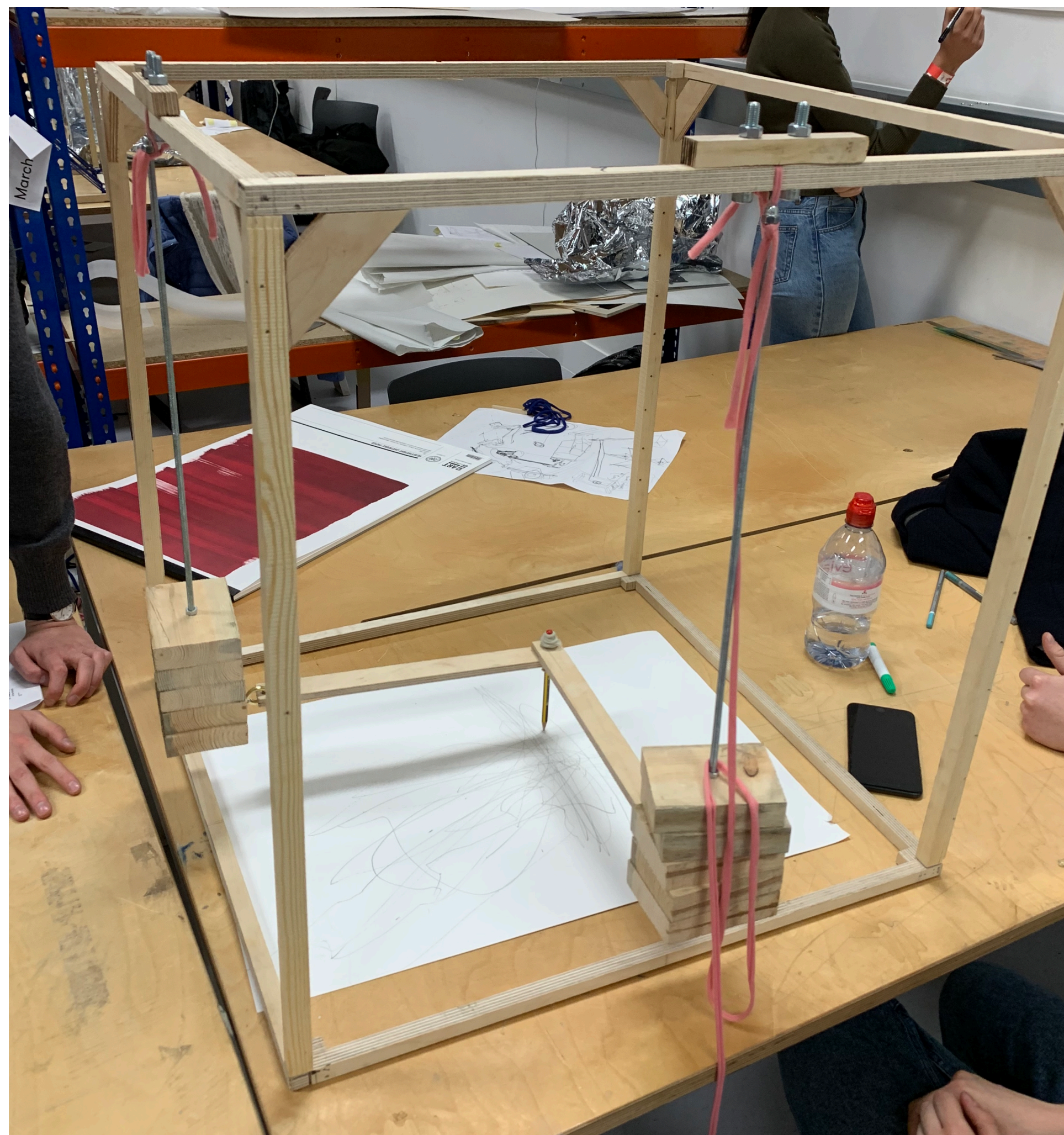

# SPIDERCAM

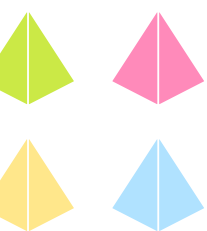
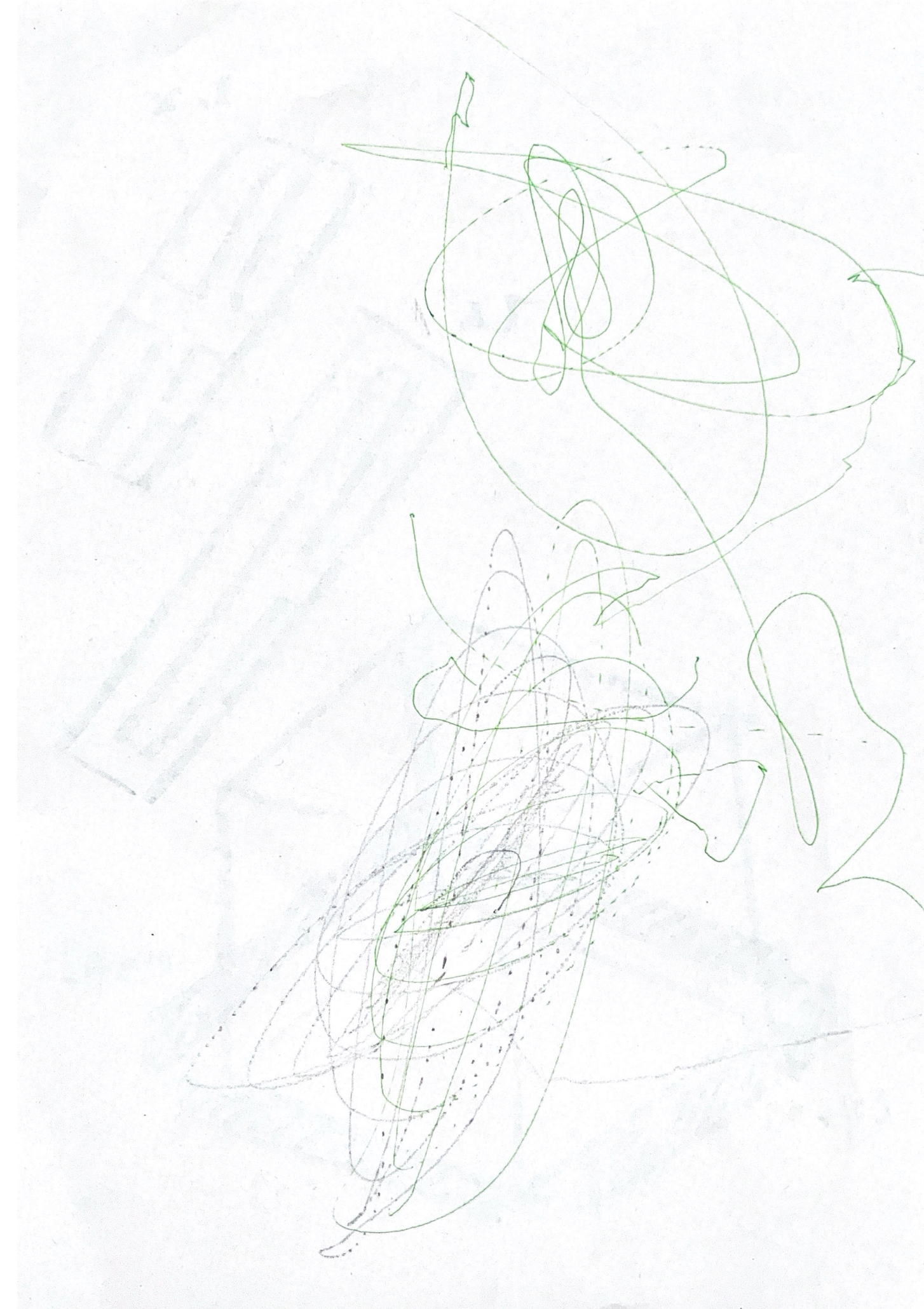
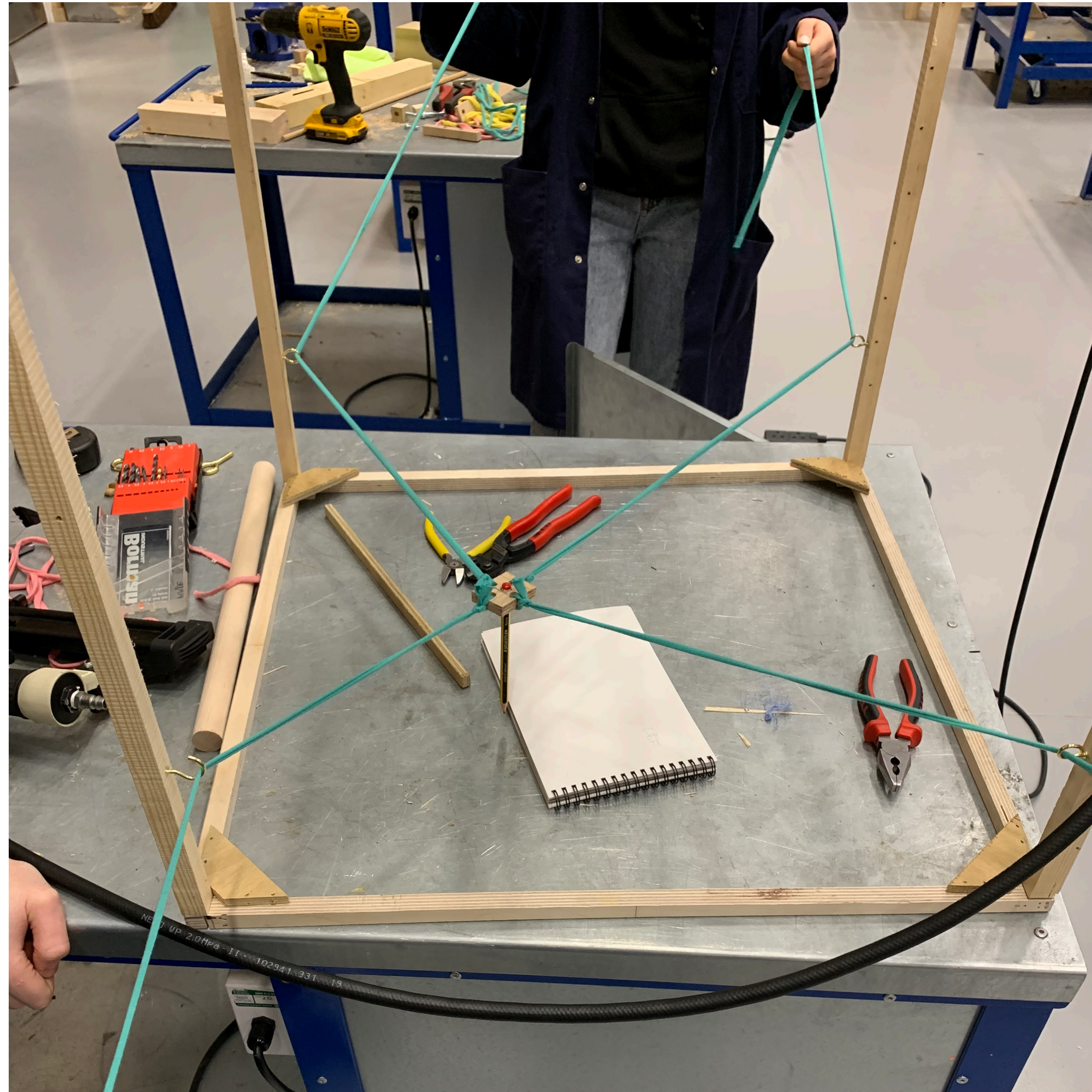

# SWINGING PLATFORM & FIXED PEN

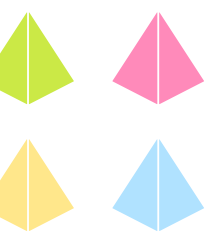
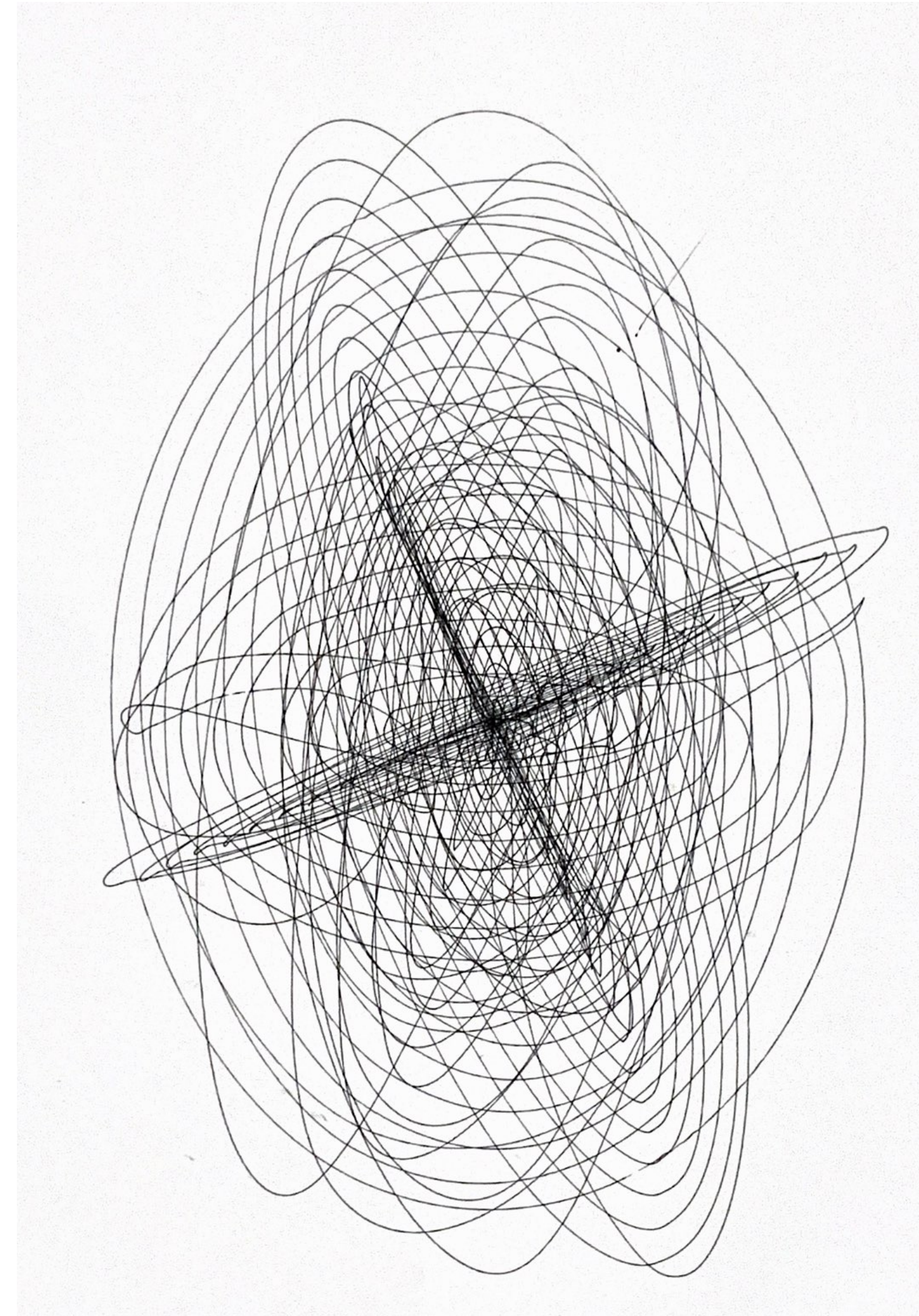
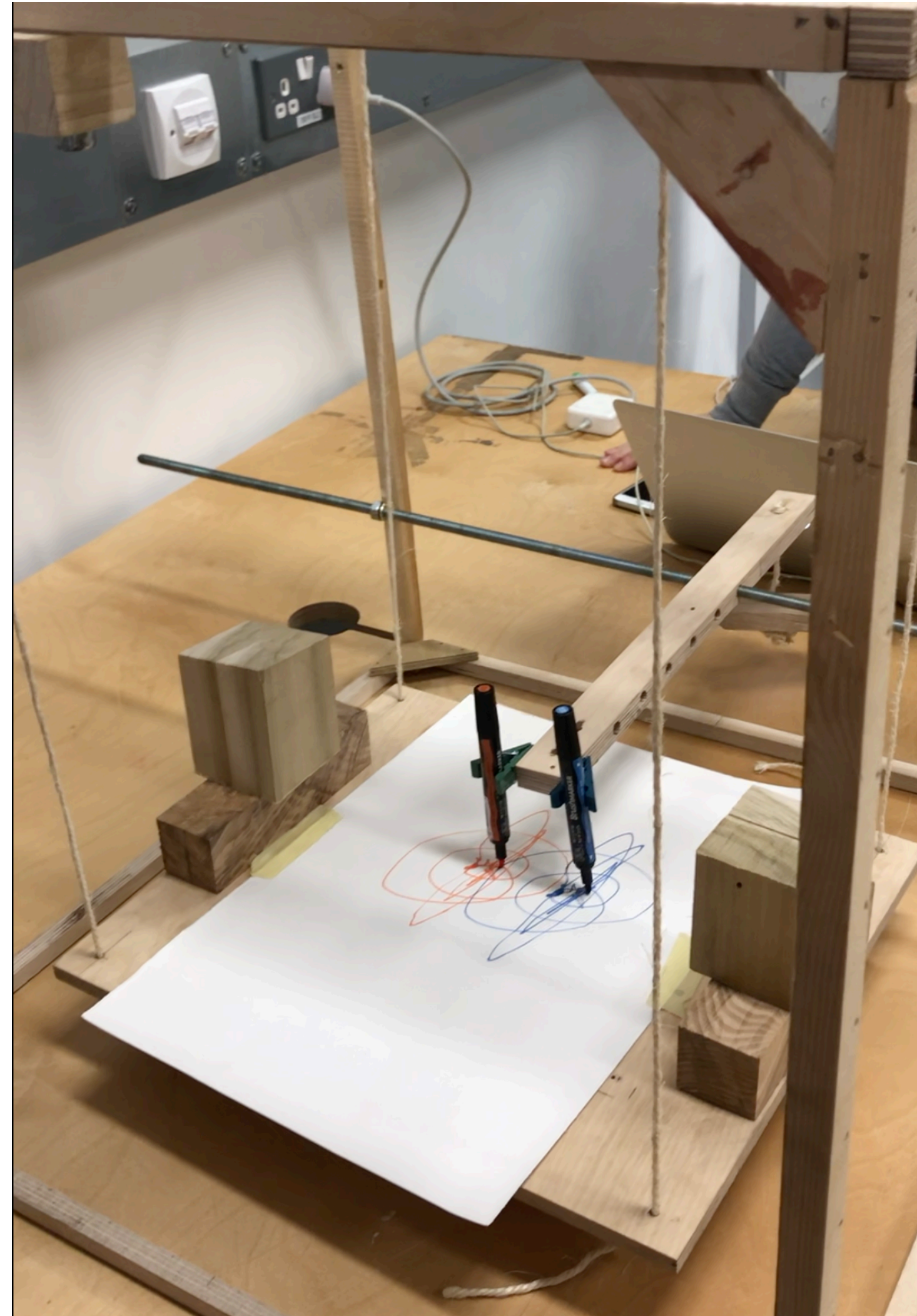

# ROTATING PLATFORM

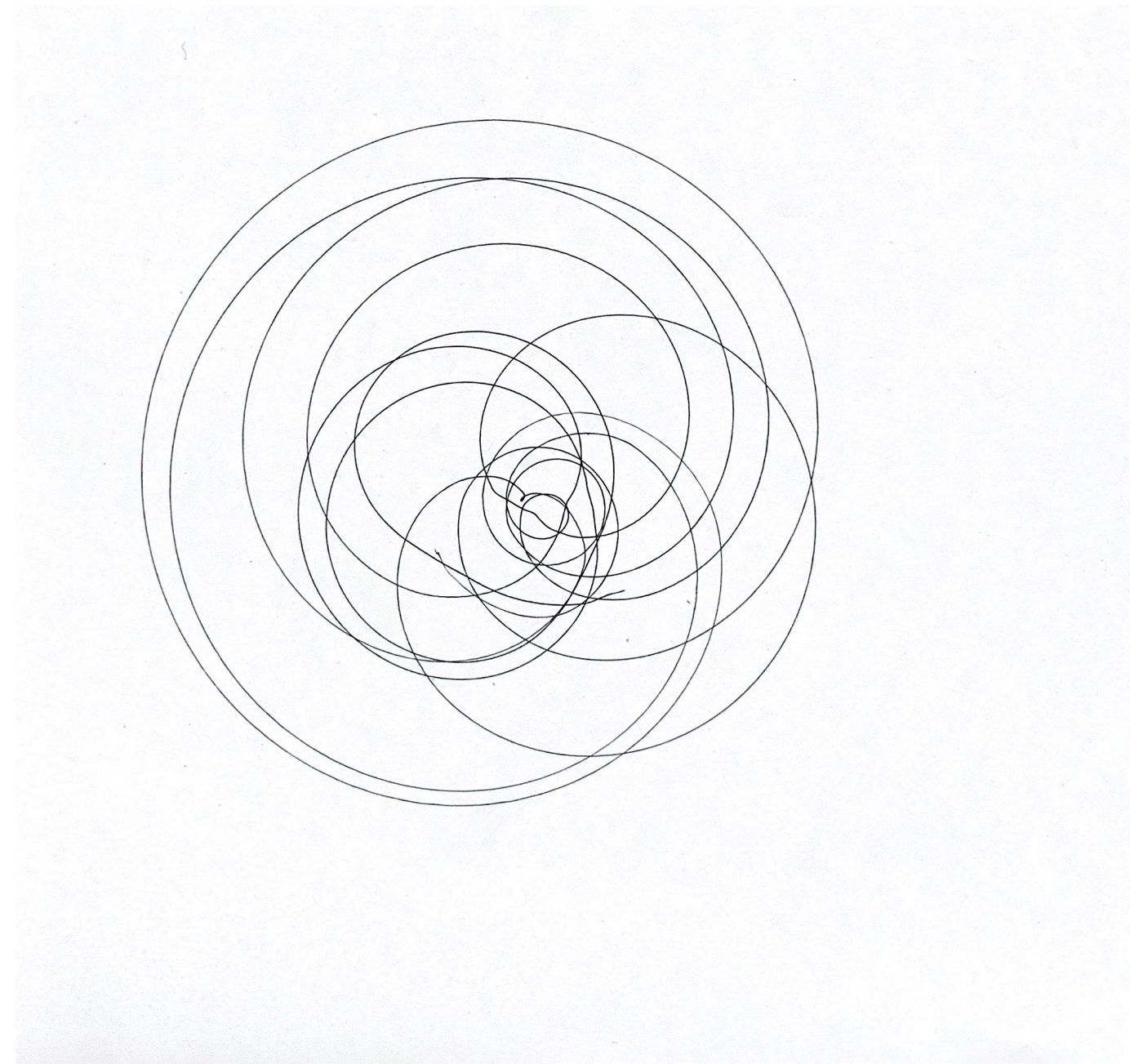

CONSTANT ROTATION

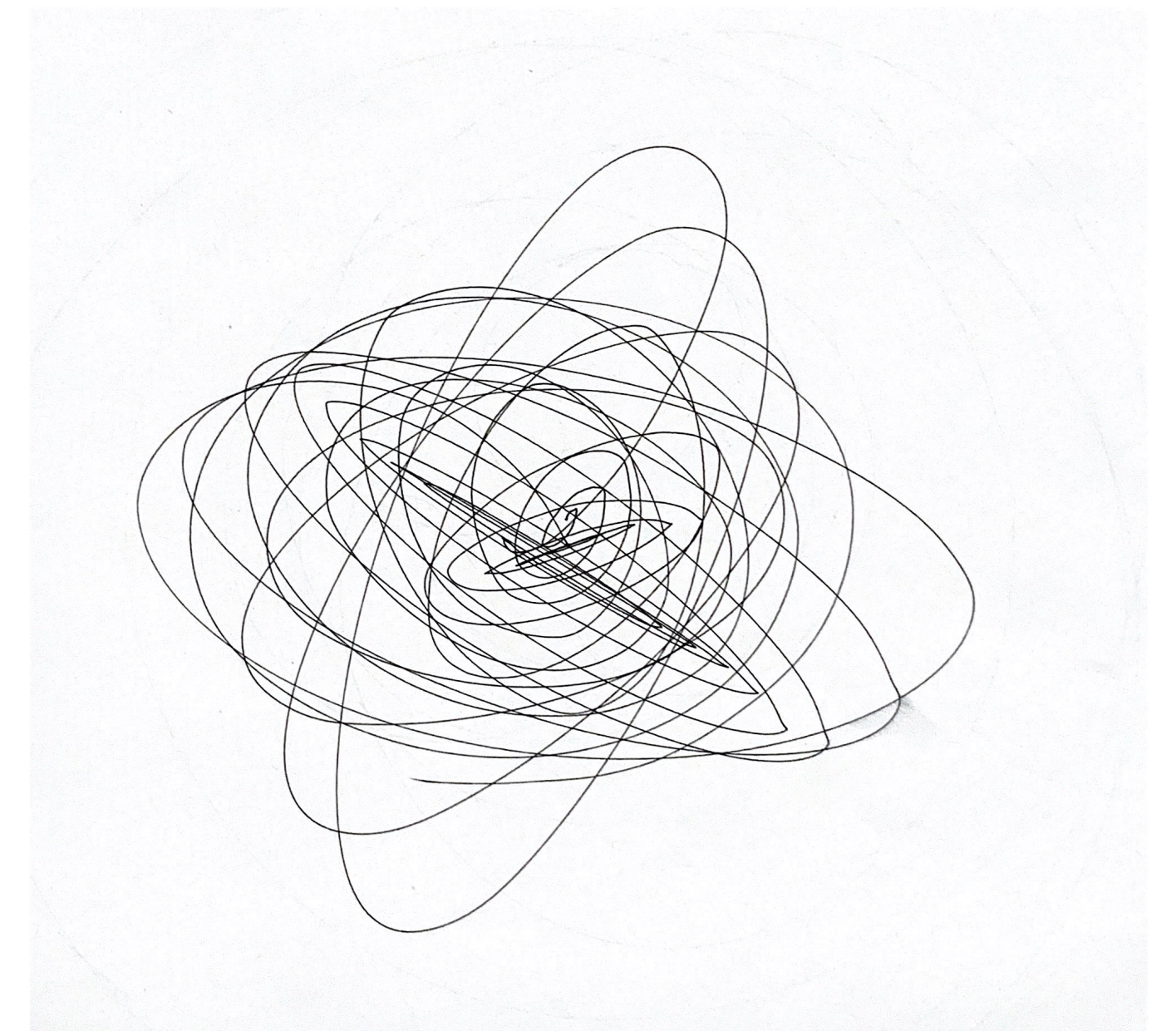
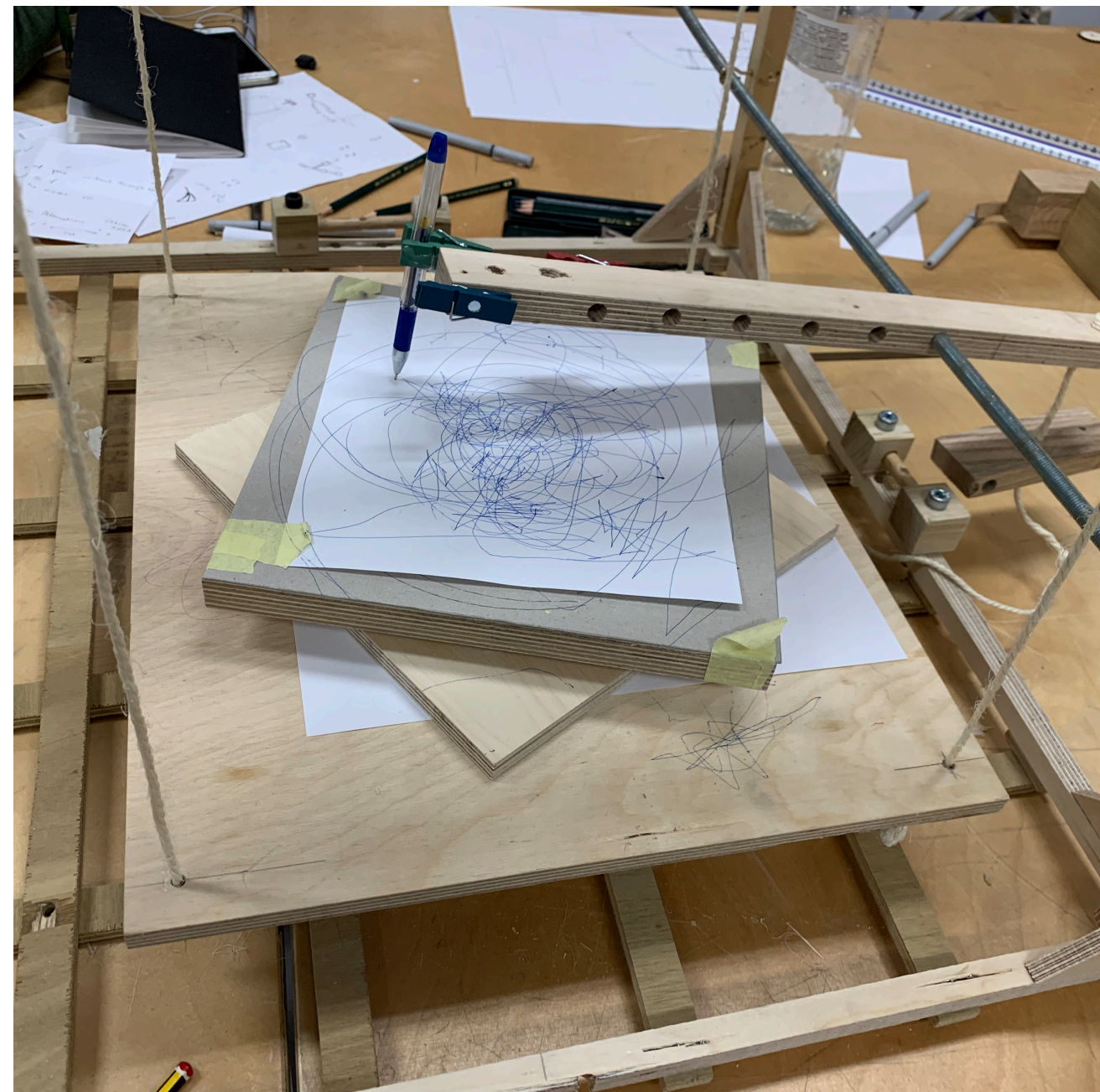

INERTIA ROTATION

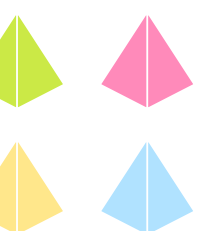

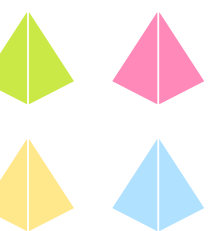

# OUR STORY

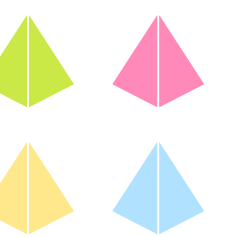
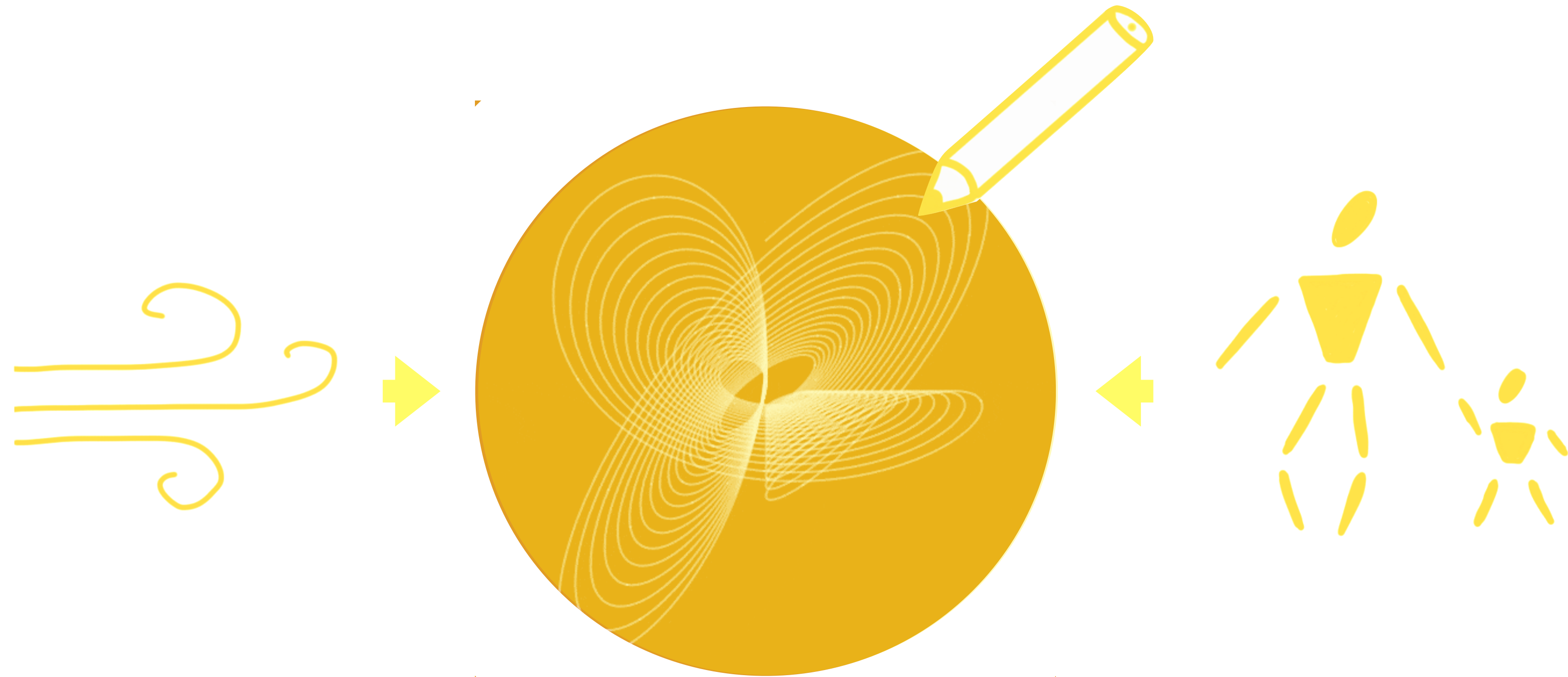

# EXPLORATION OF MEDIUMS

PEN

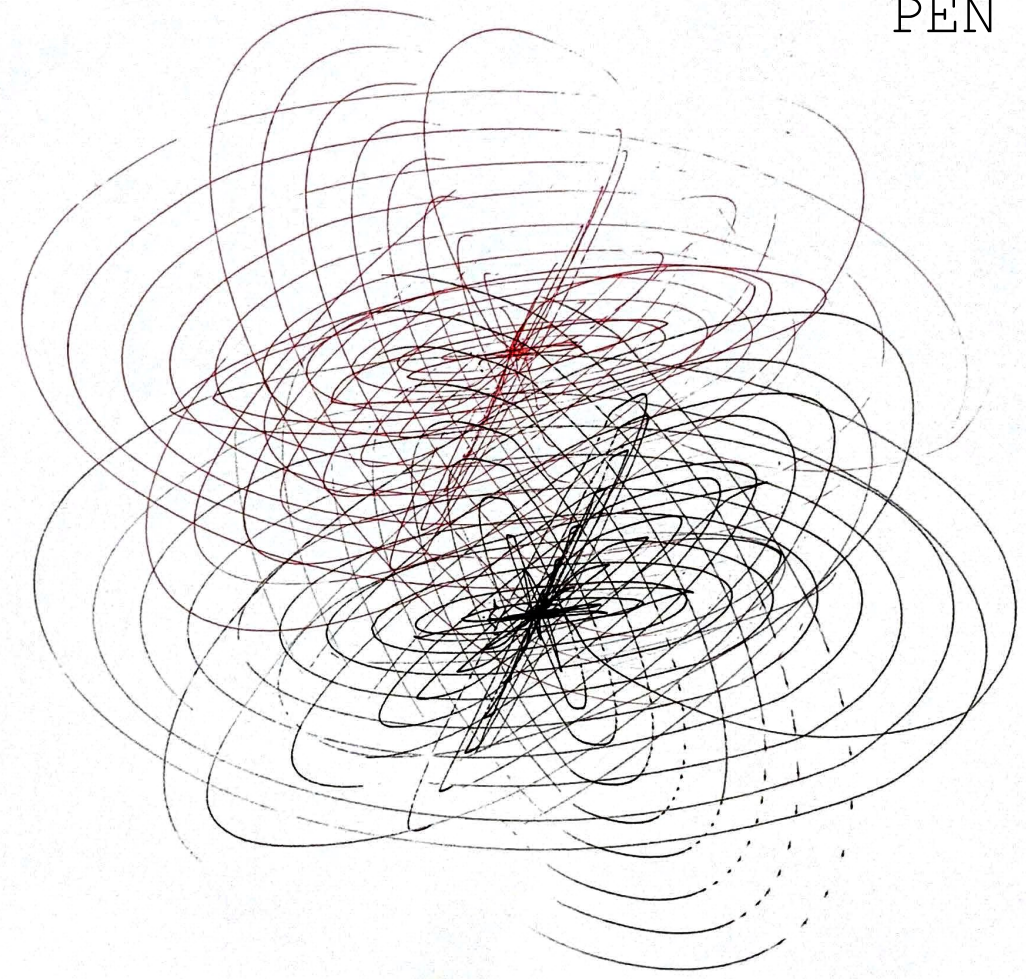

PEN

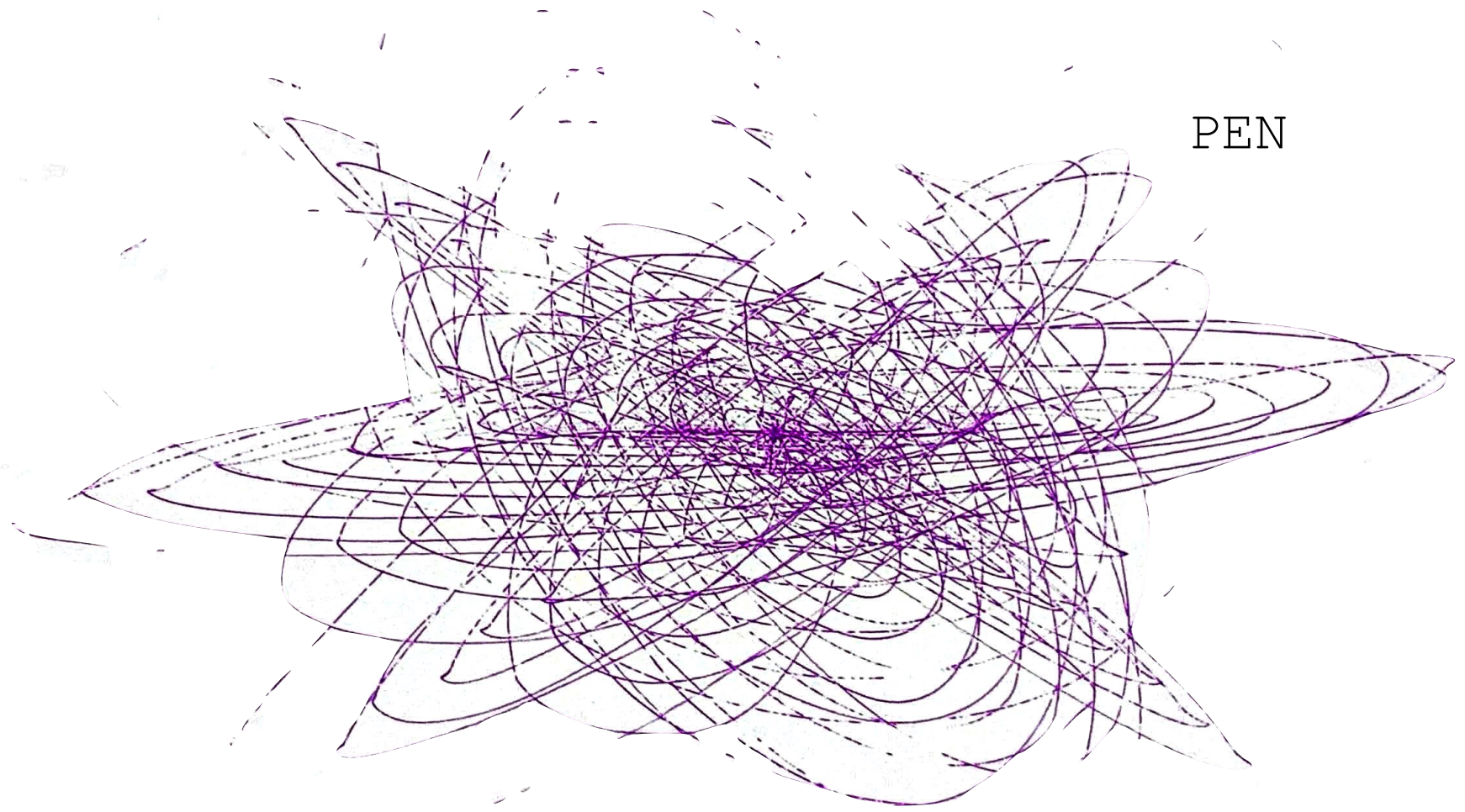

PEN

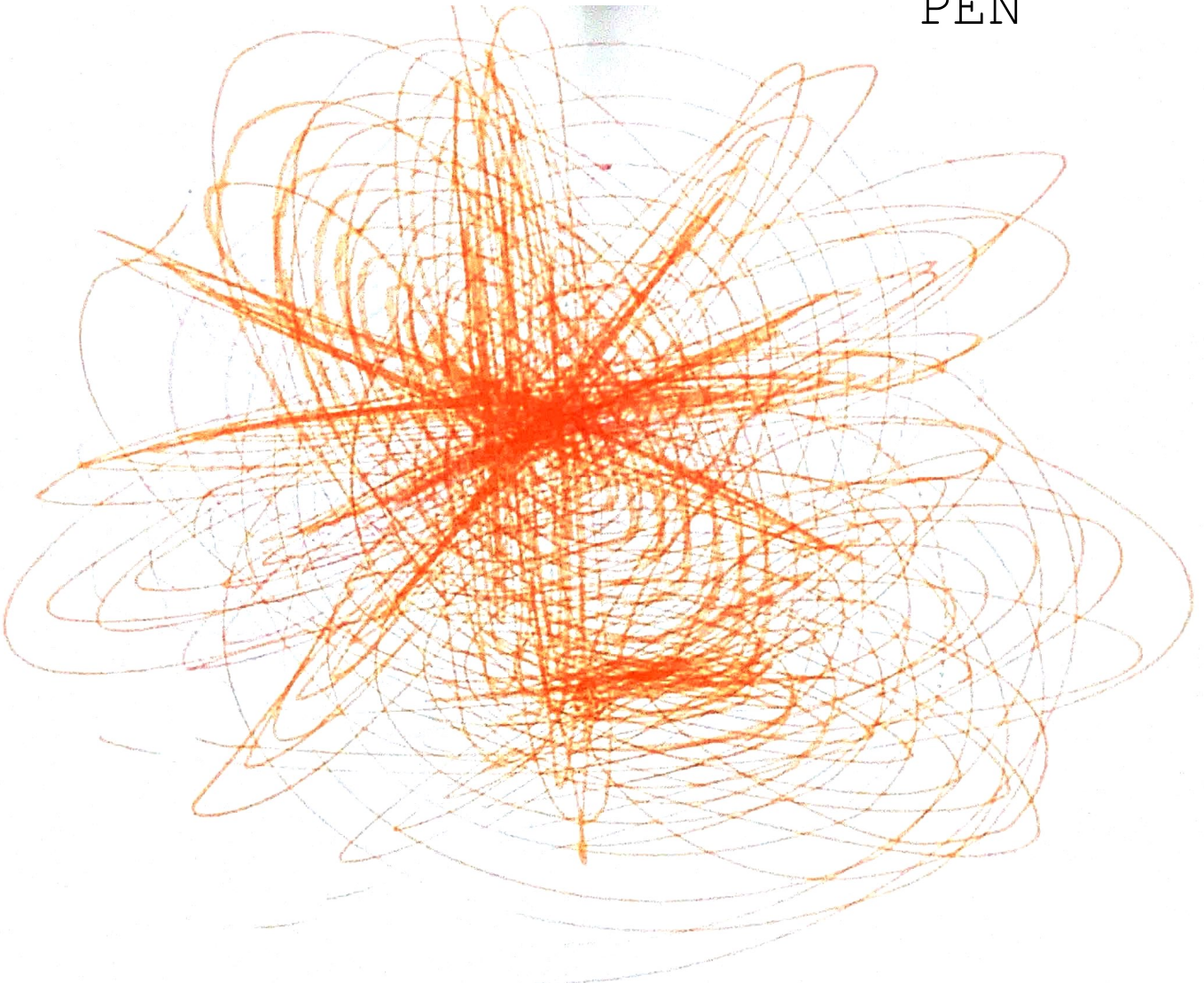

MARKER

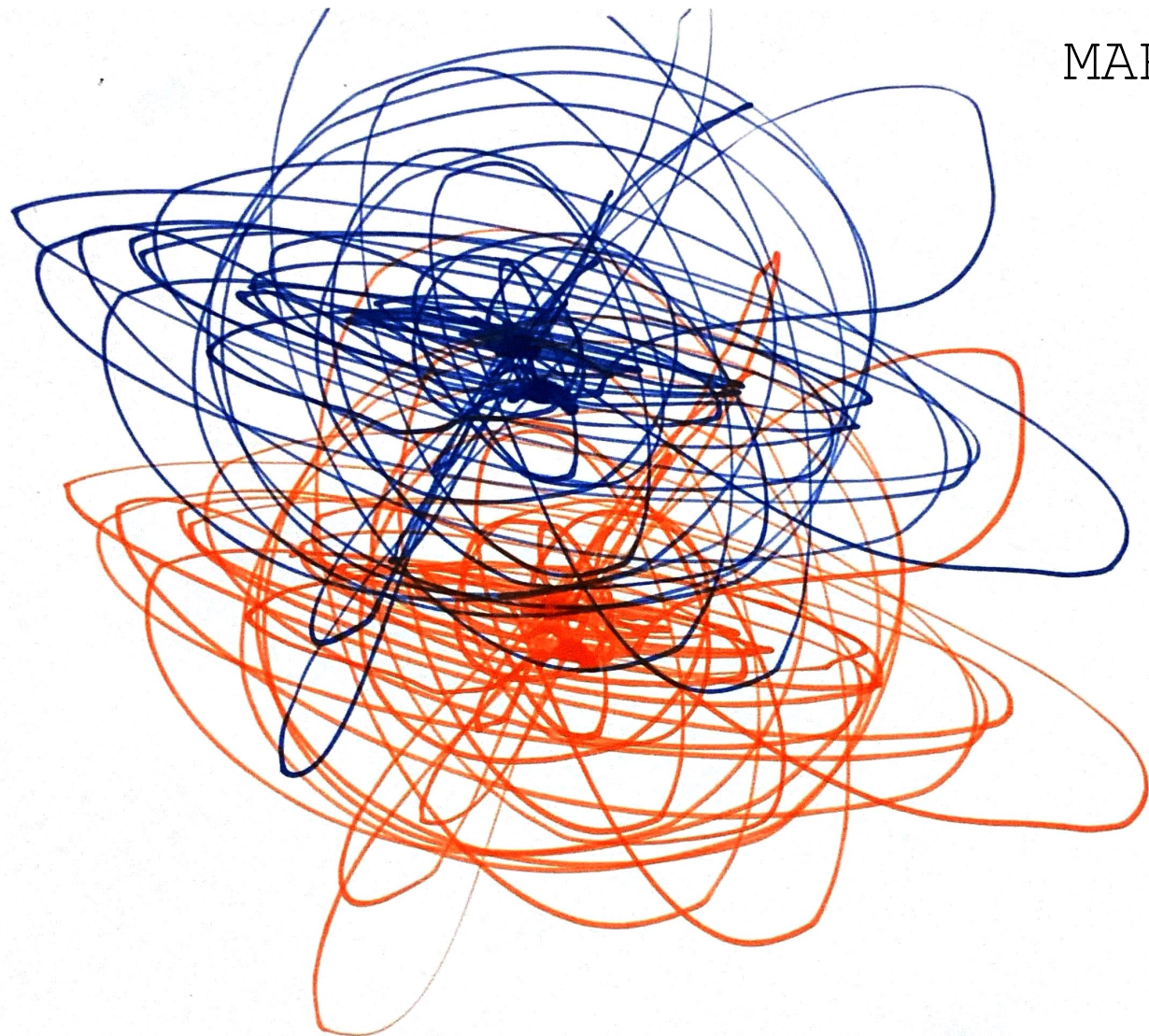

WATERCOLORS

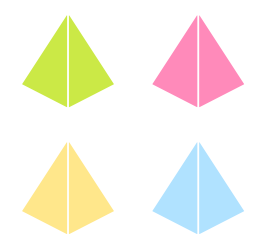
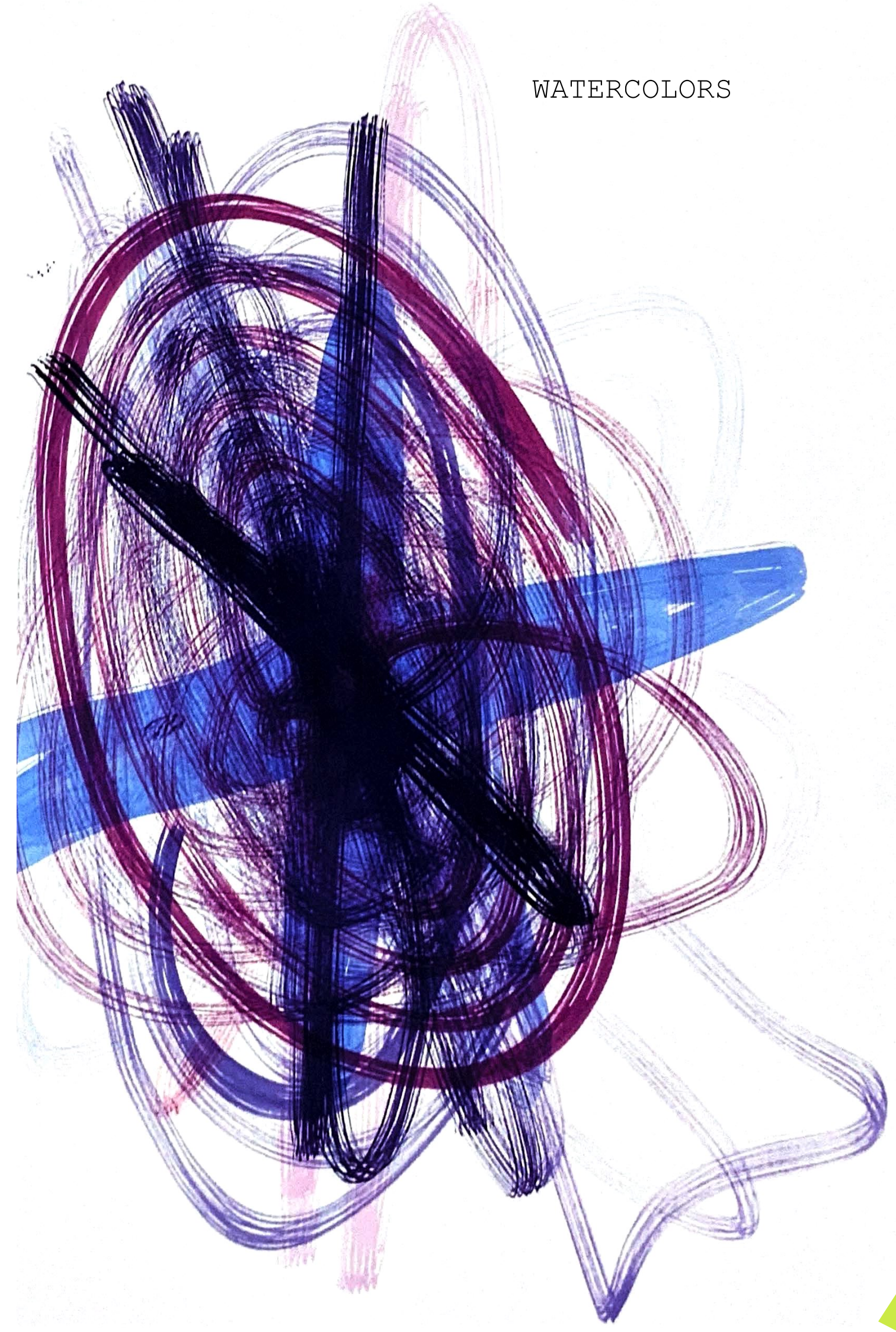

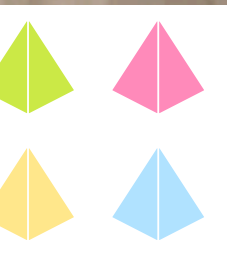
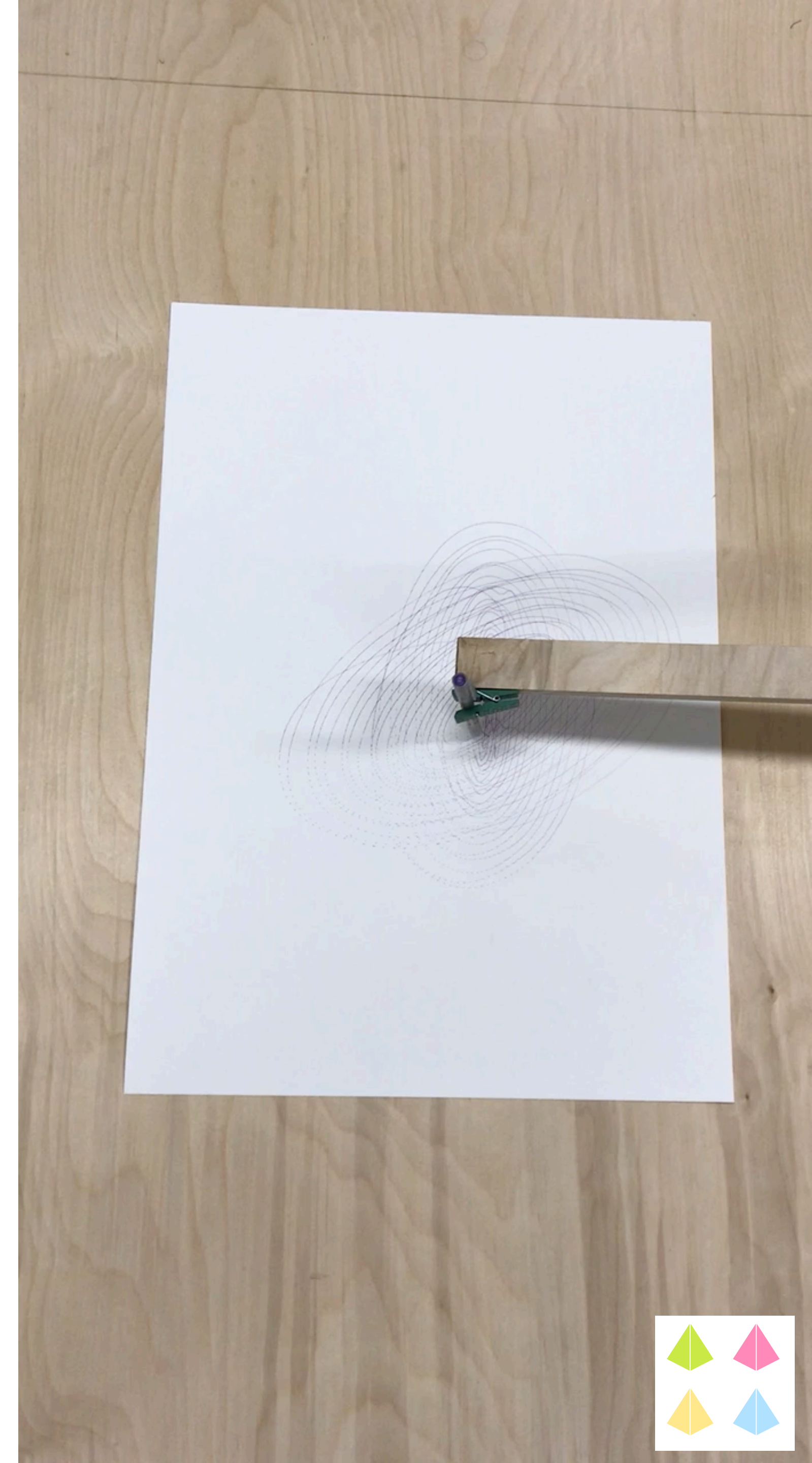
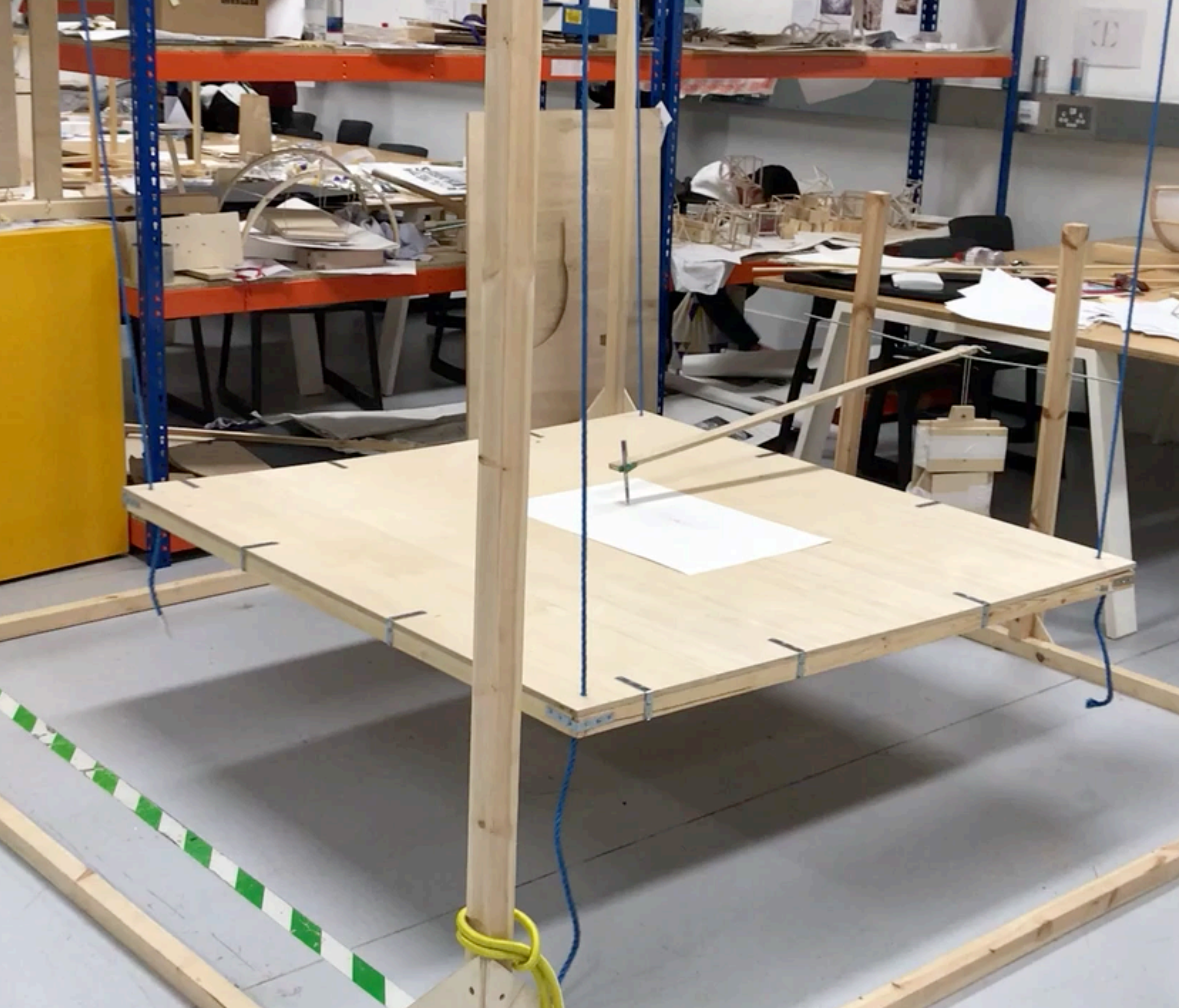

# STRUCTURE DESIGN

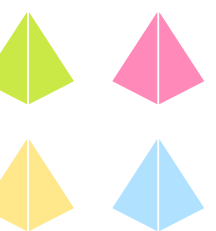
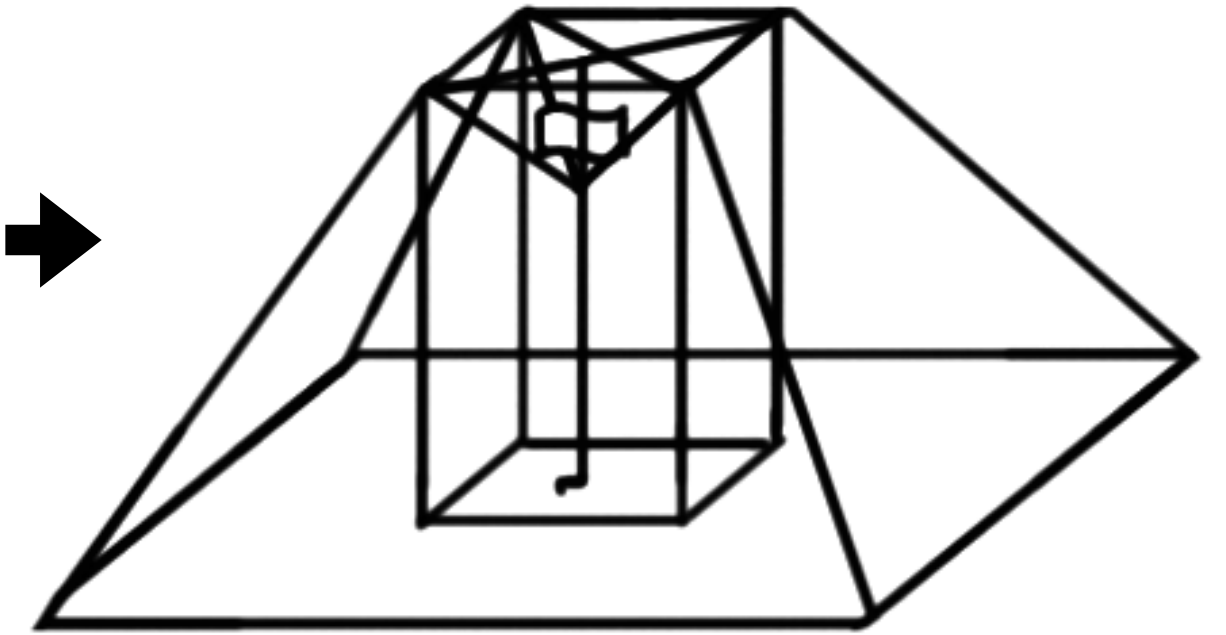
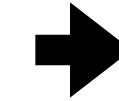
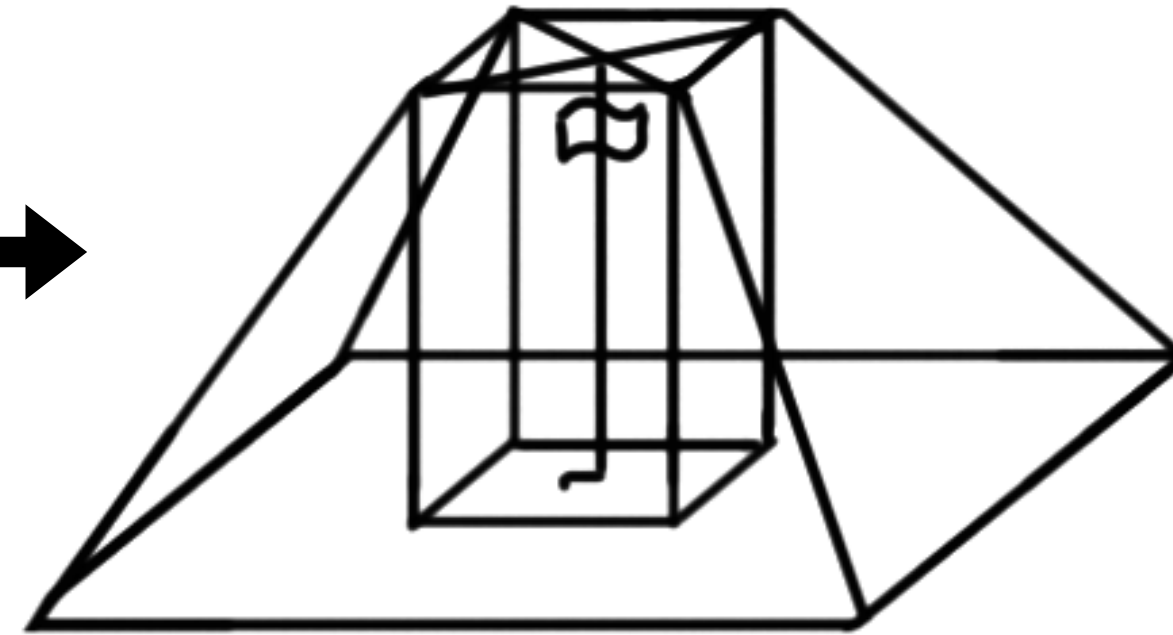
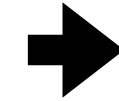
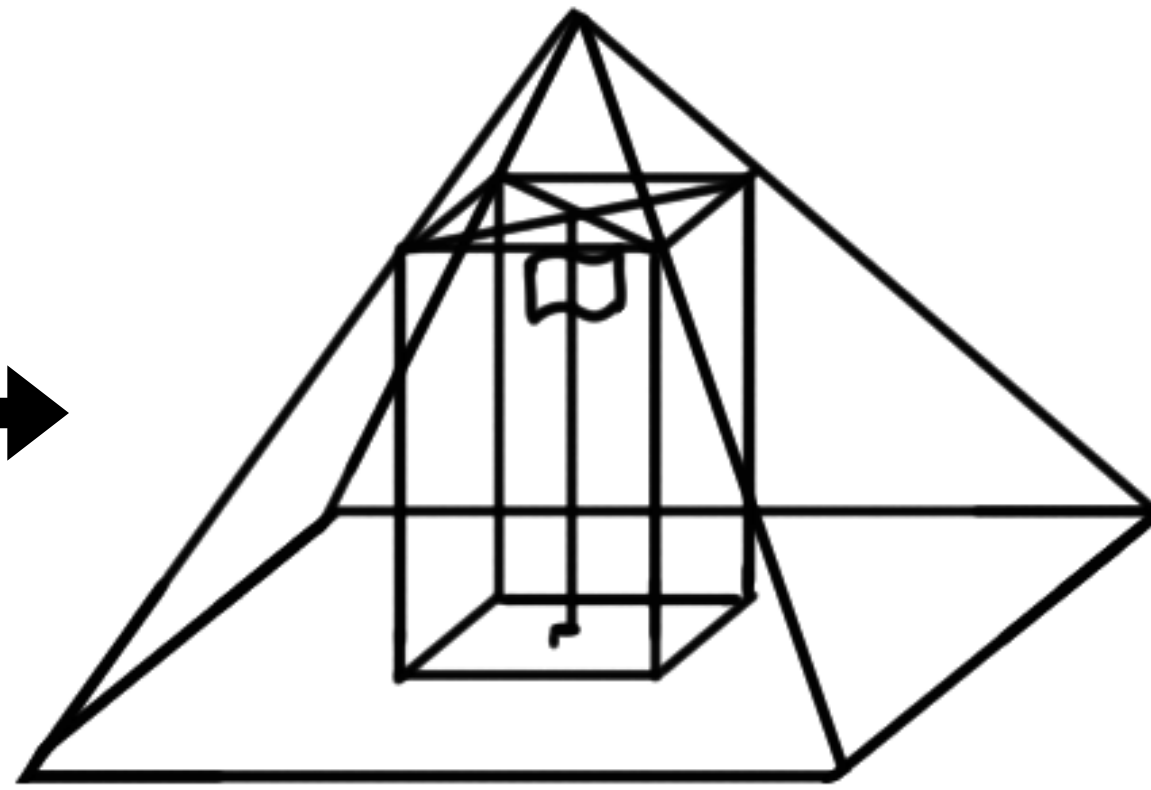
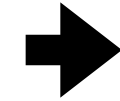
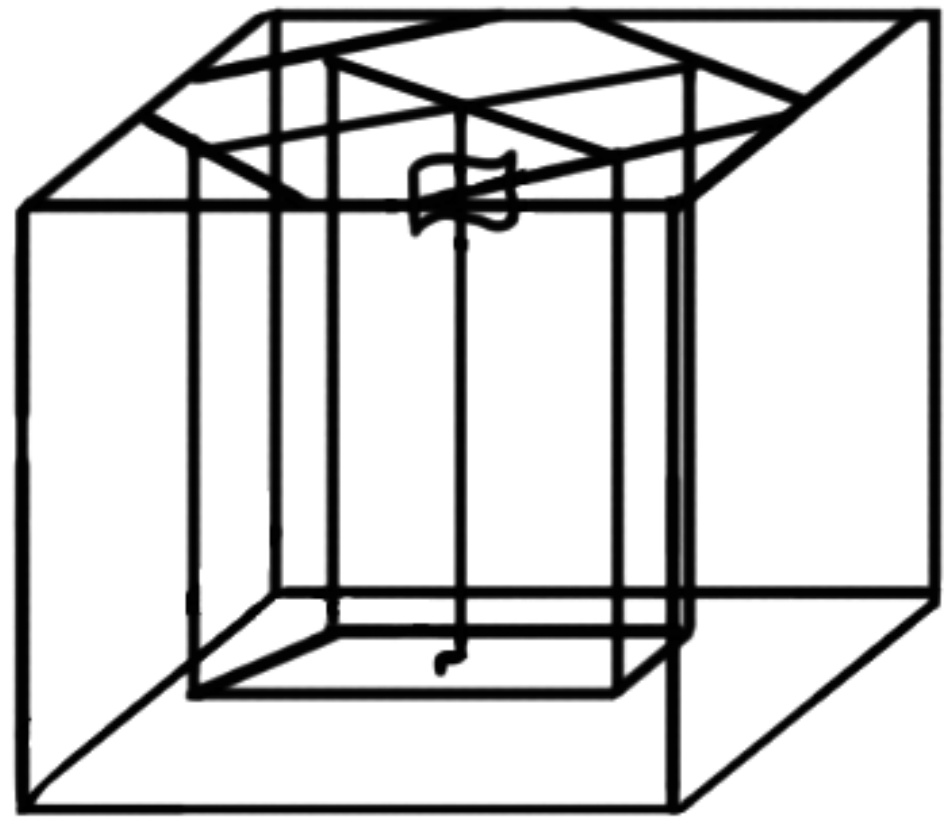

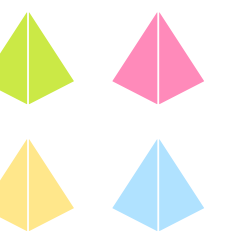
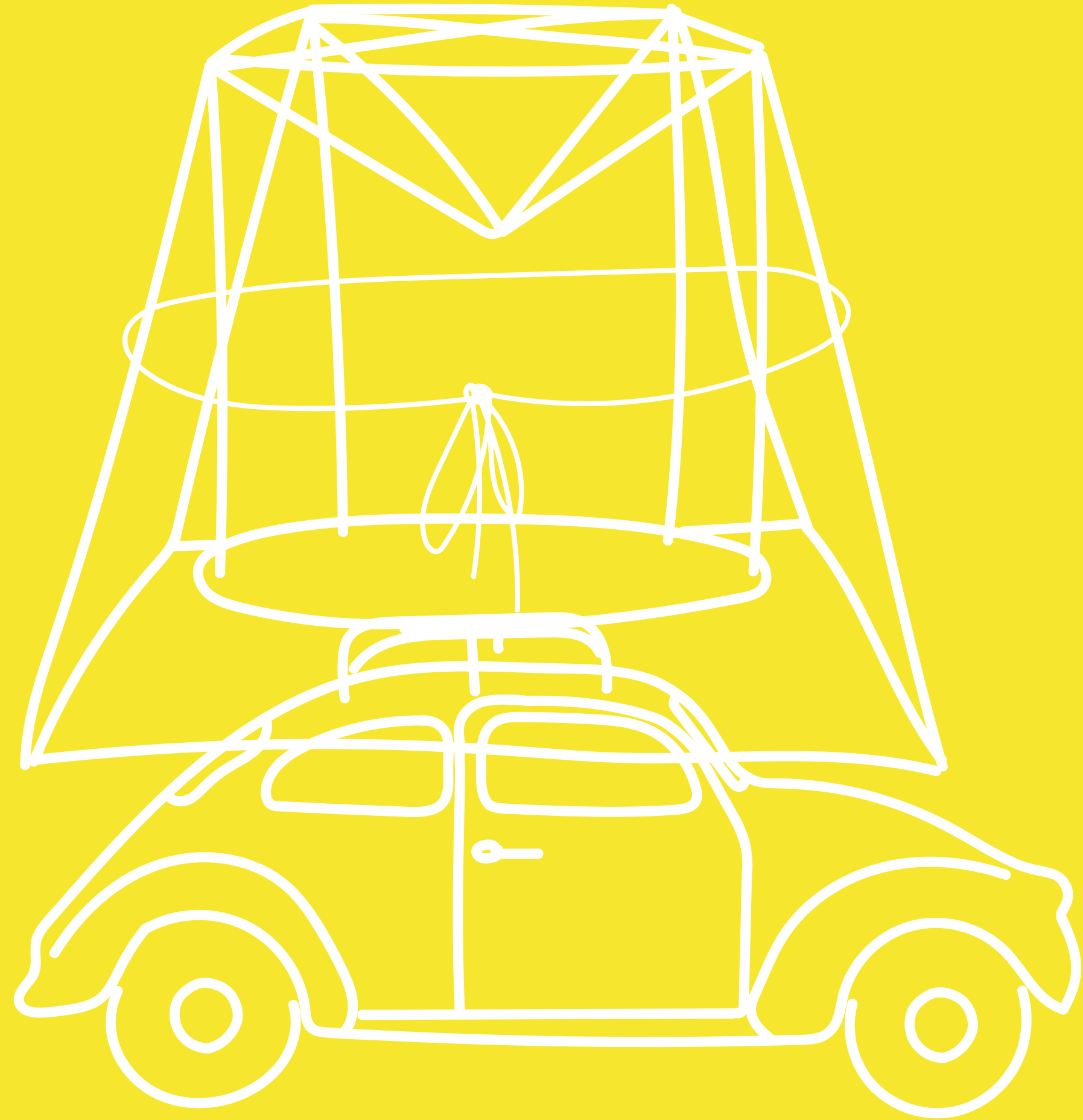

# FOLDABLE STRUCTURE

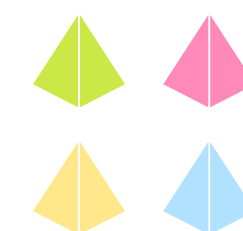

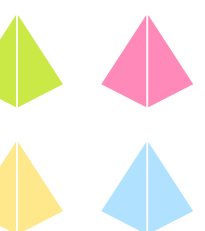
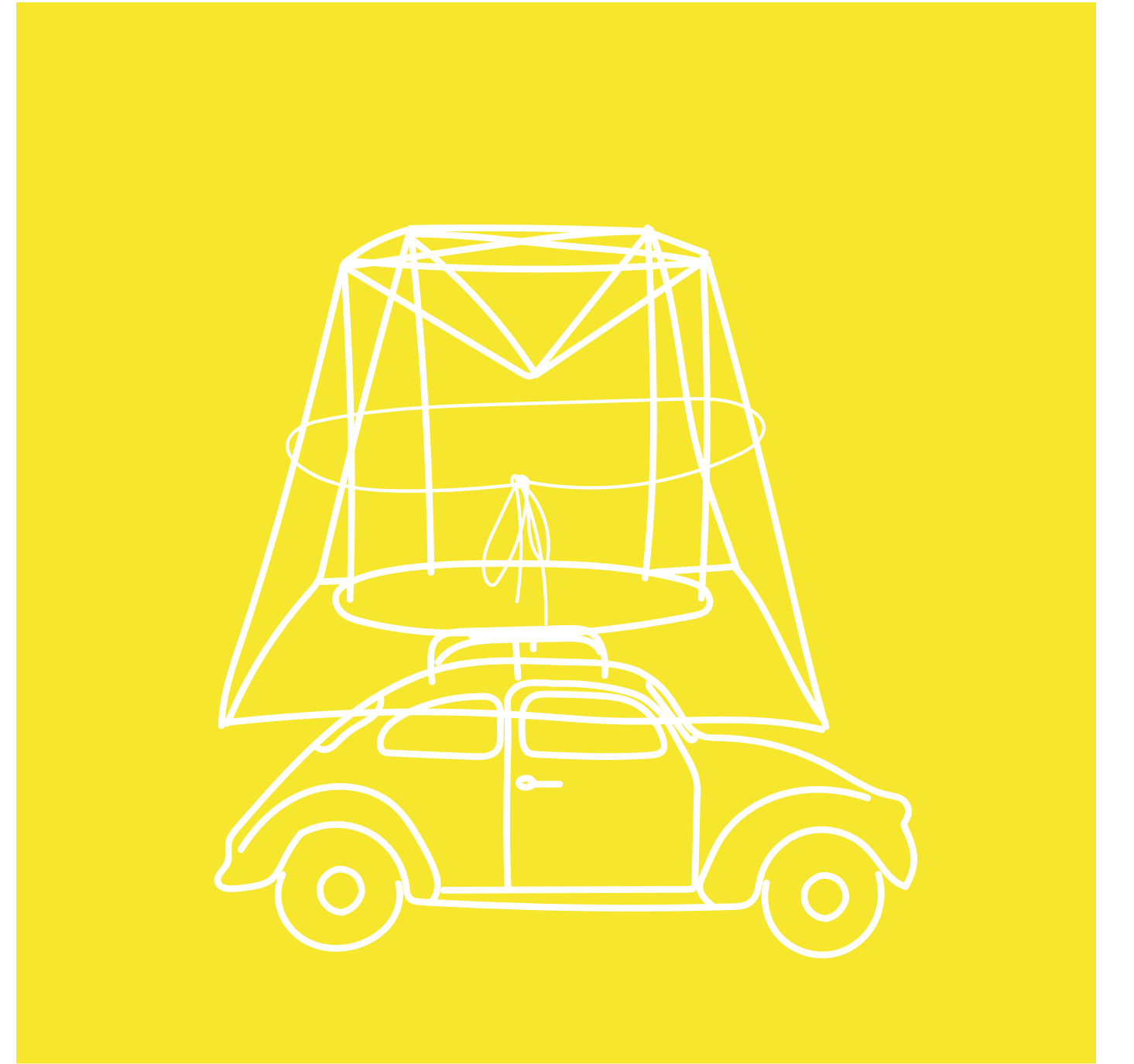

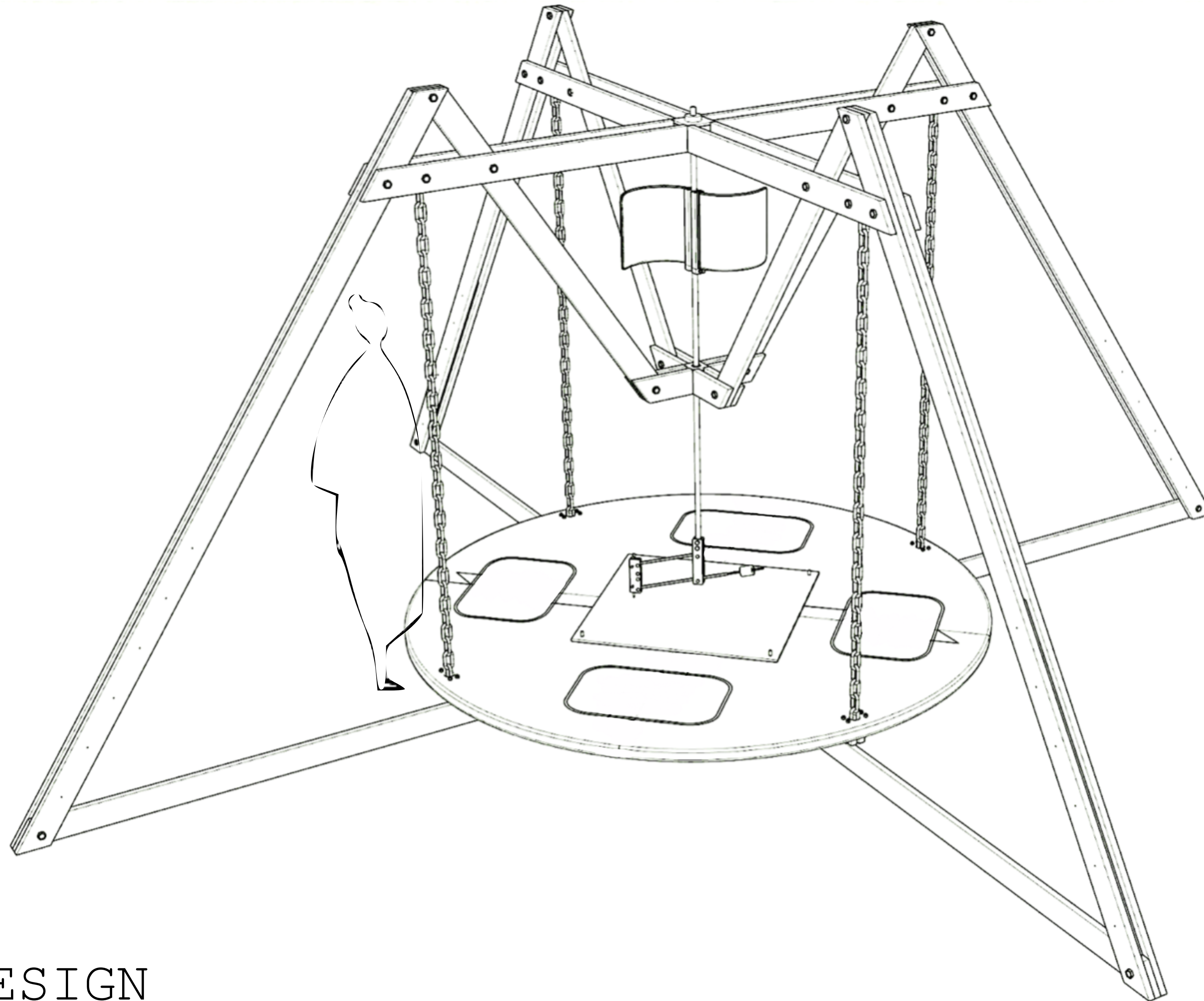

FINAL DESIGN

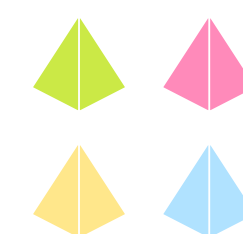

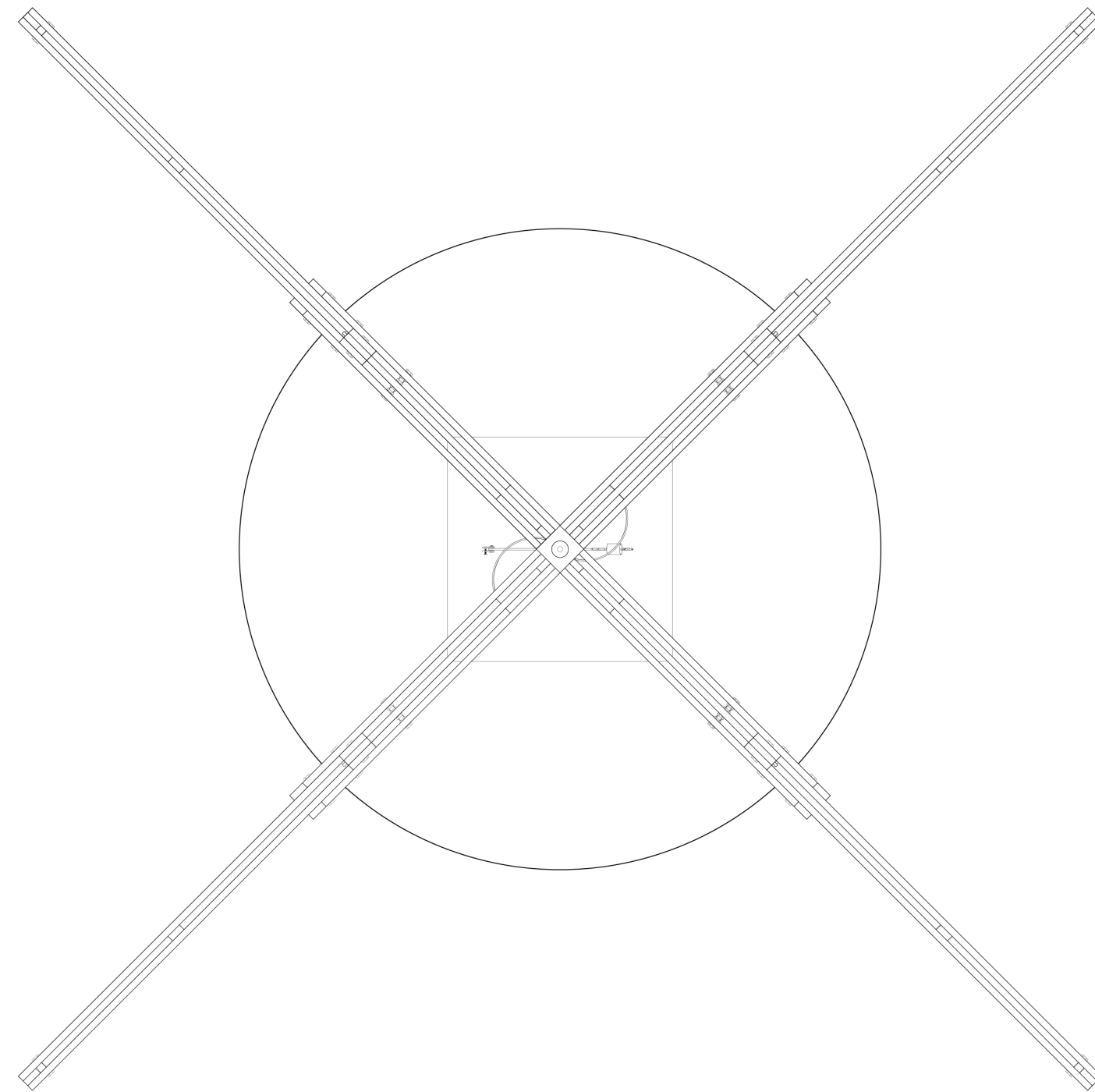

PLAN  
1:10 A1

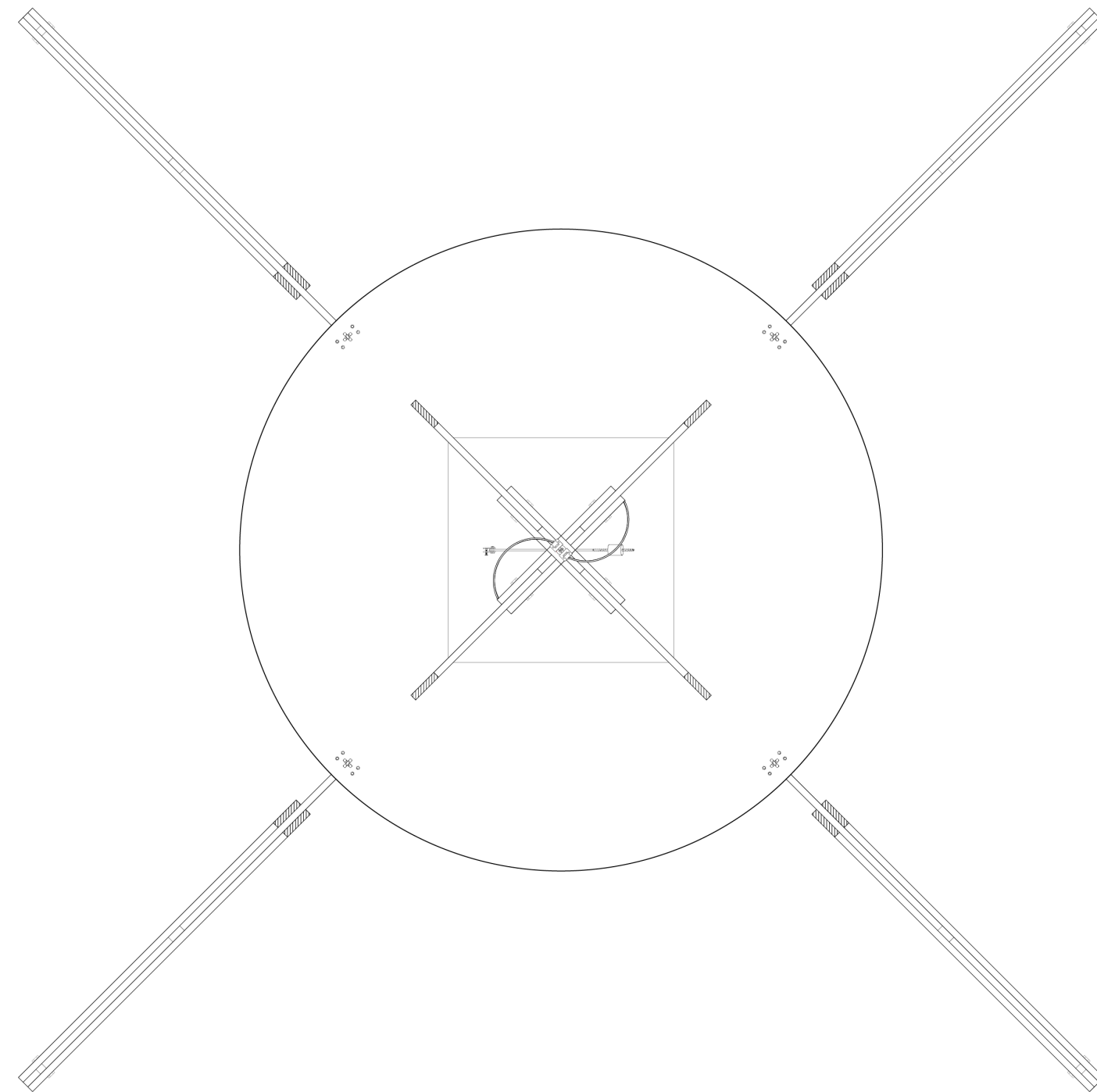

Plan Cutview 1  
1:10 A1

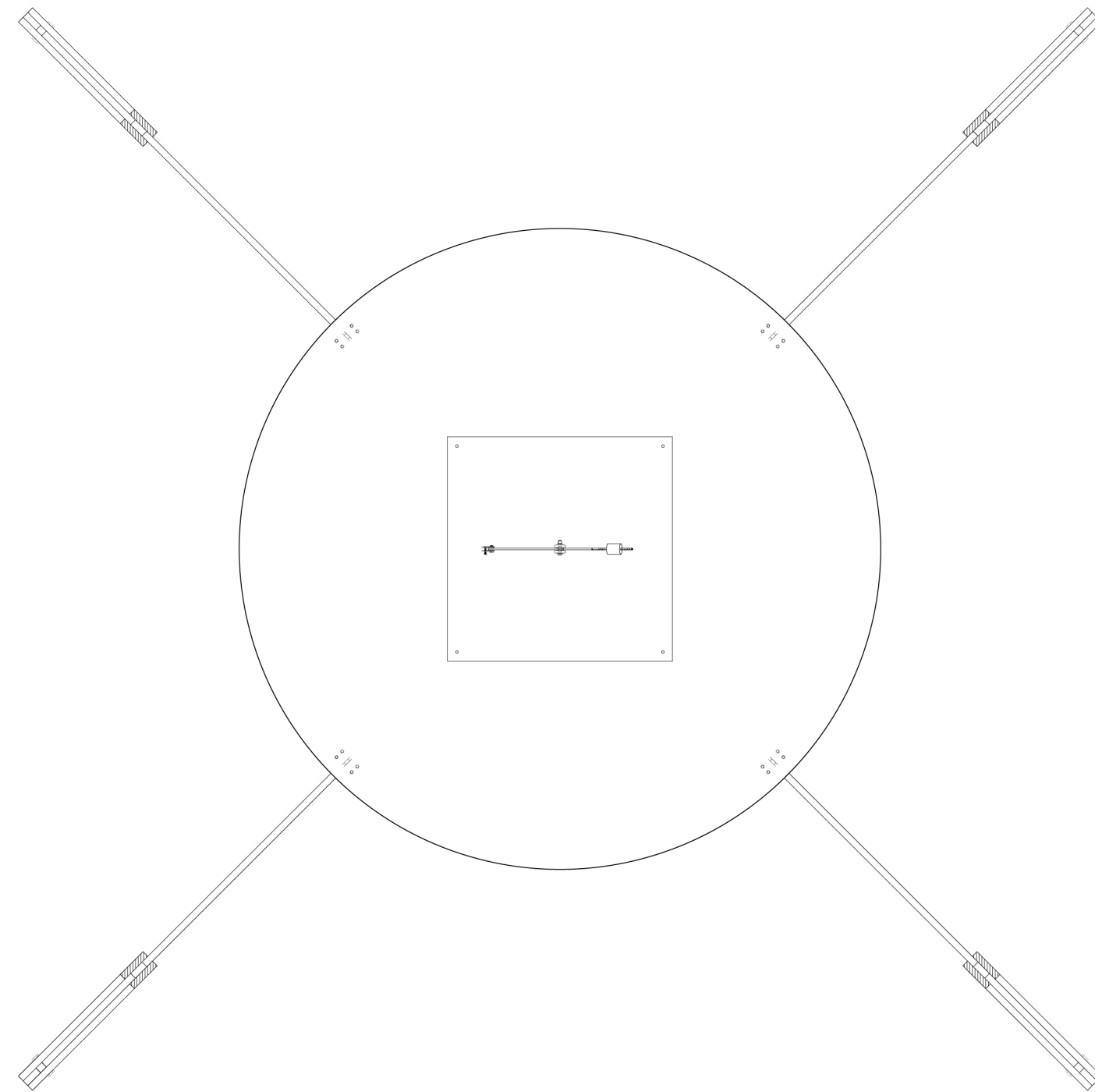

Plan Cutview 2  
1:10 A1

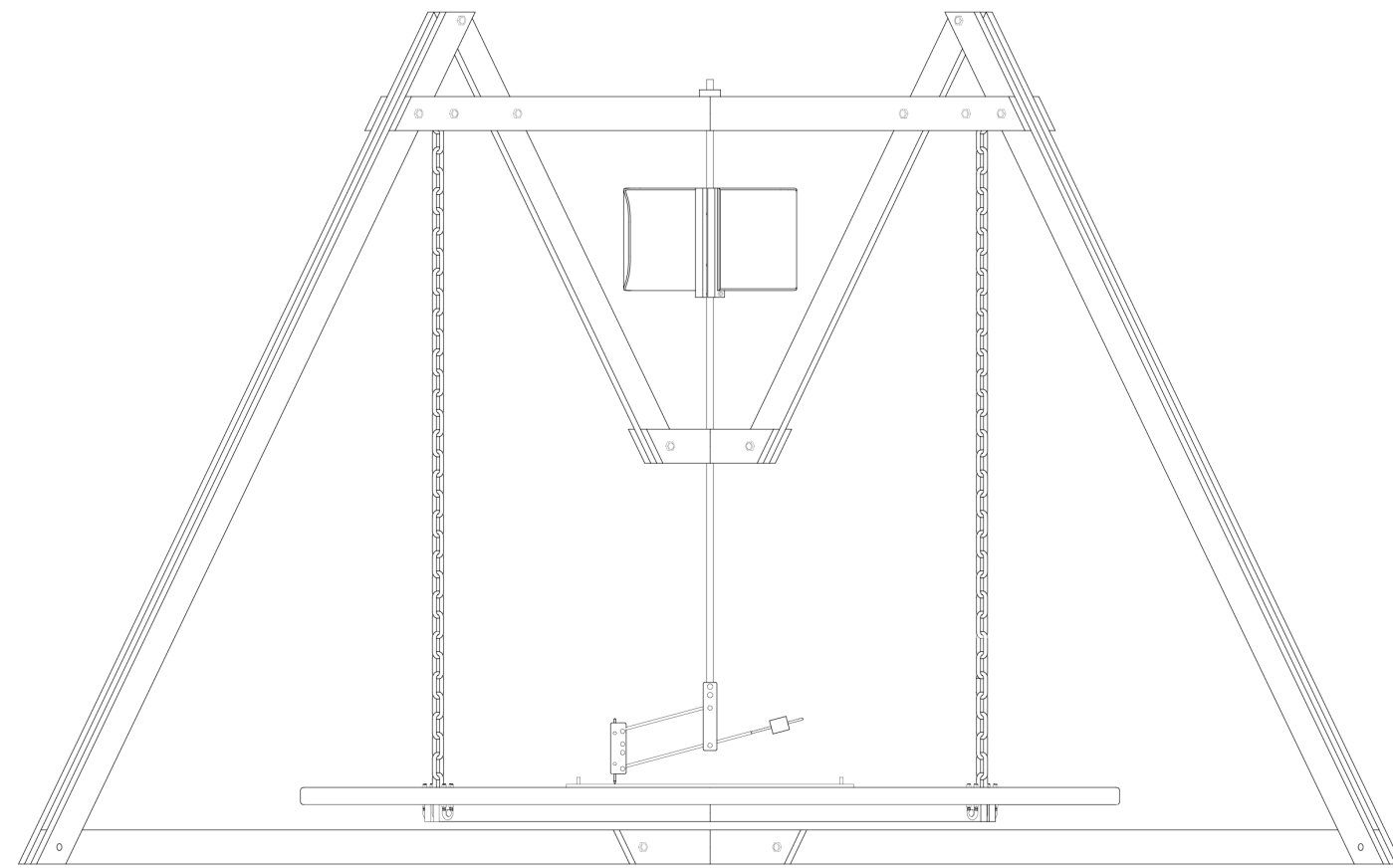

Elevation  
1:10 A1

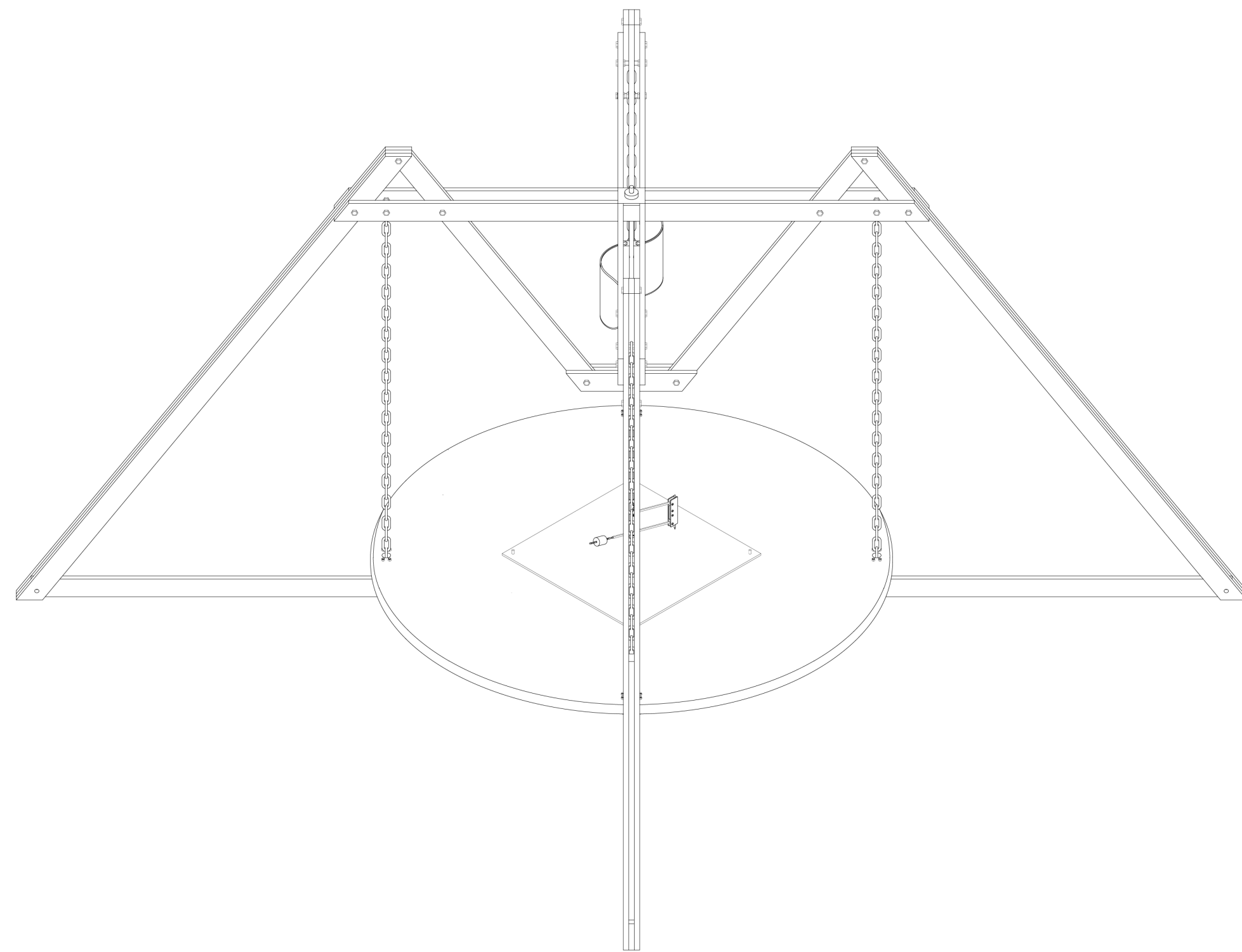

Isometric  
1:10 A1

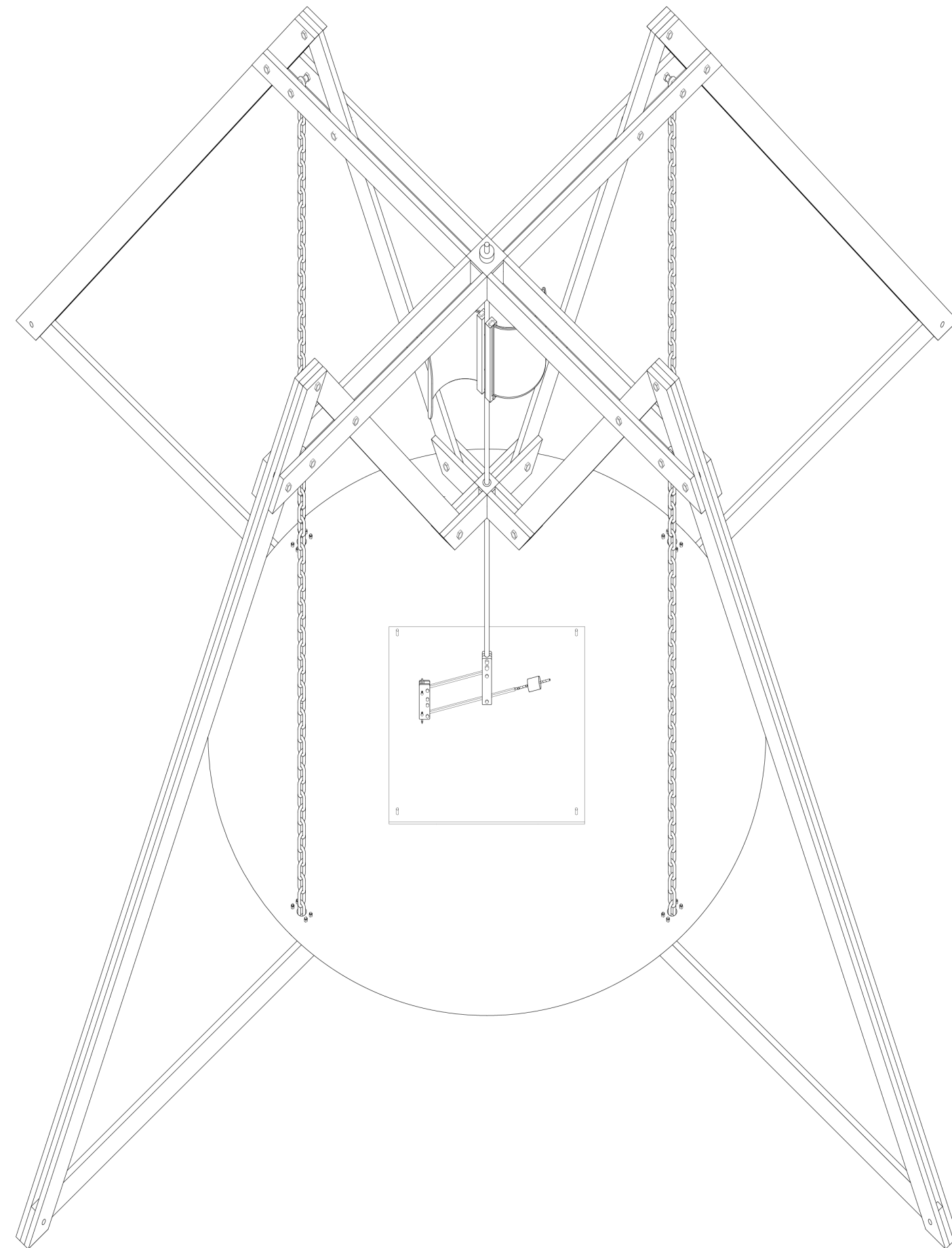

Axonometric  
1:10 A1

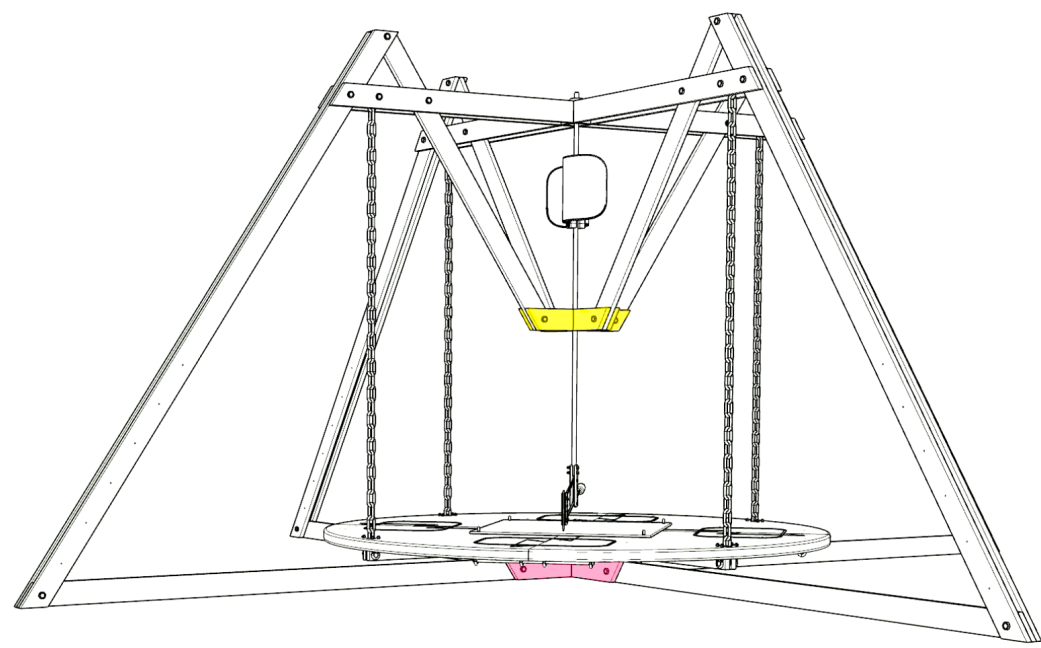

BOTTOM "X" JOINT

TOP "M" JOINT

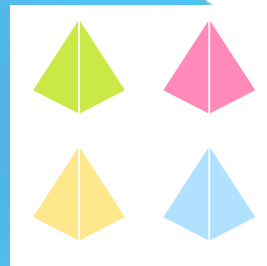
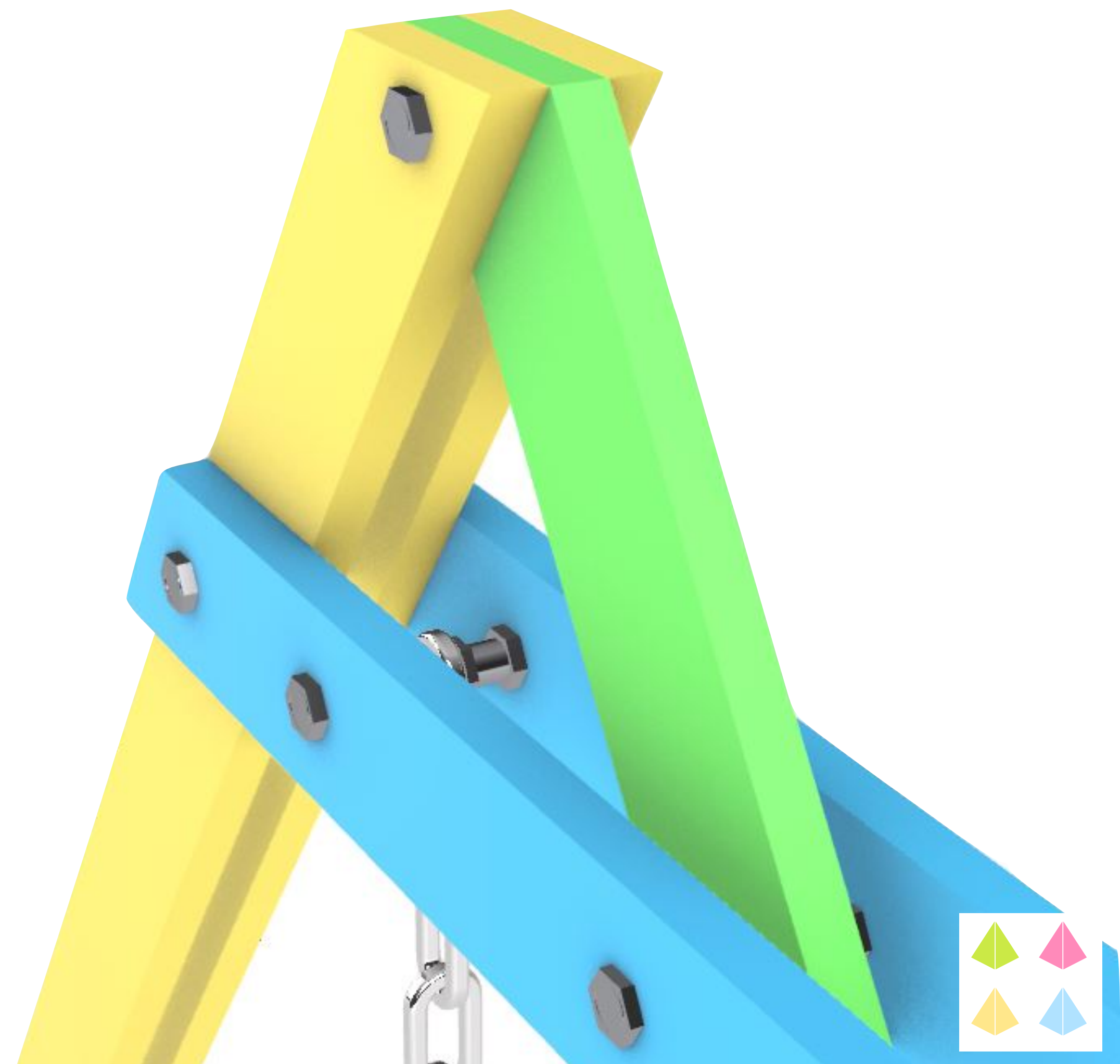
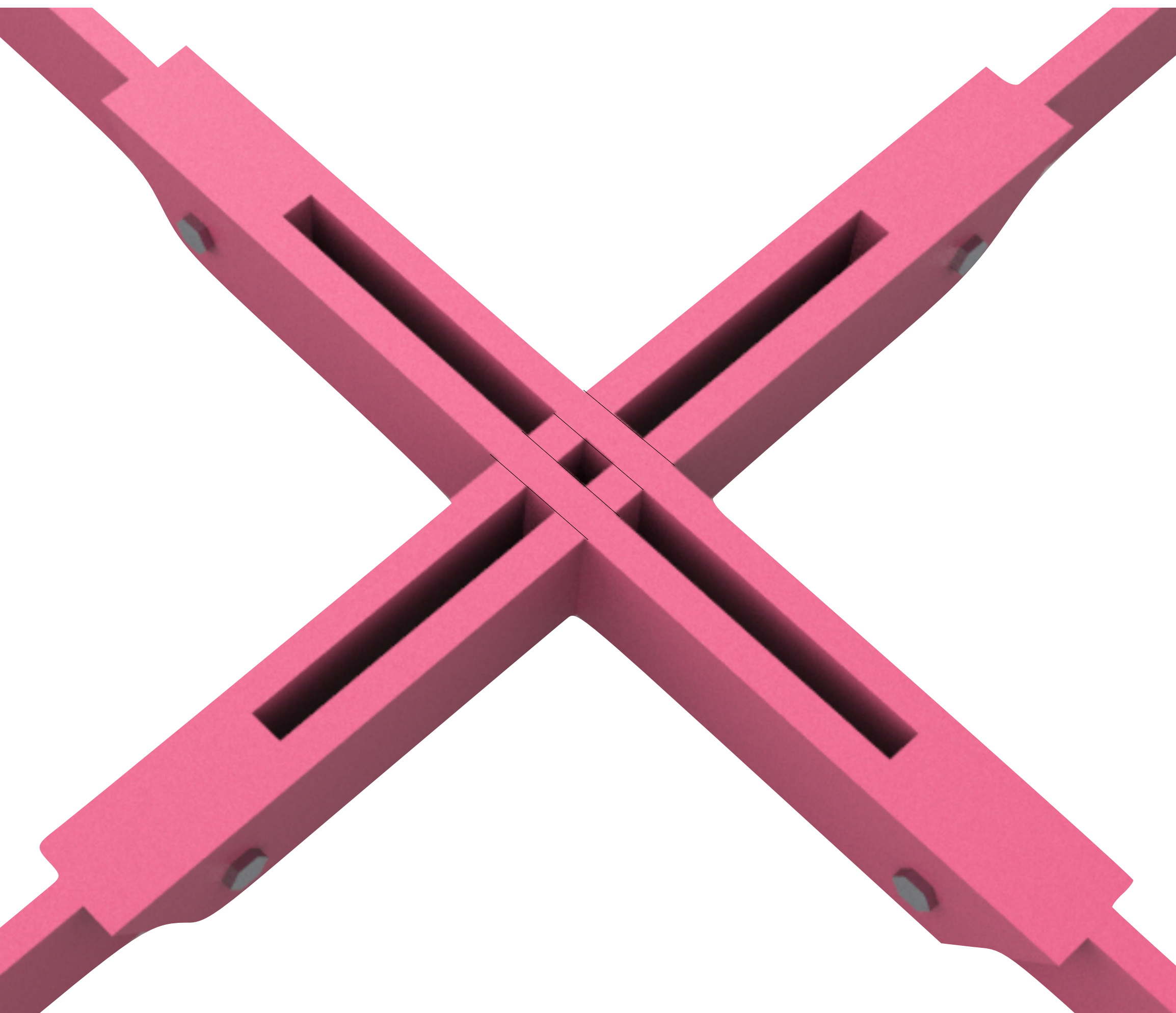
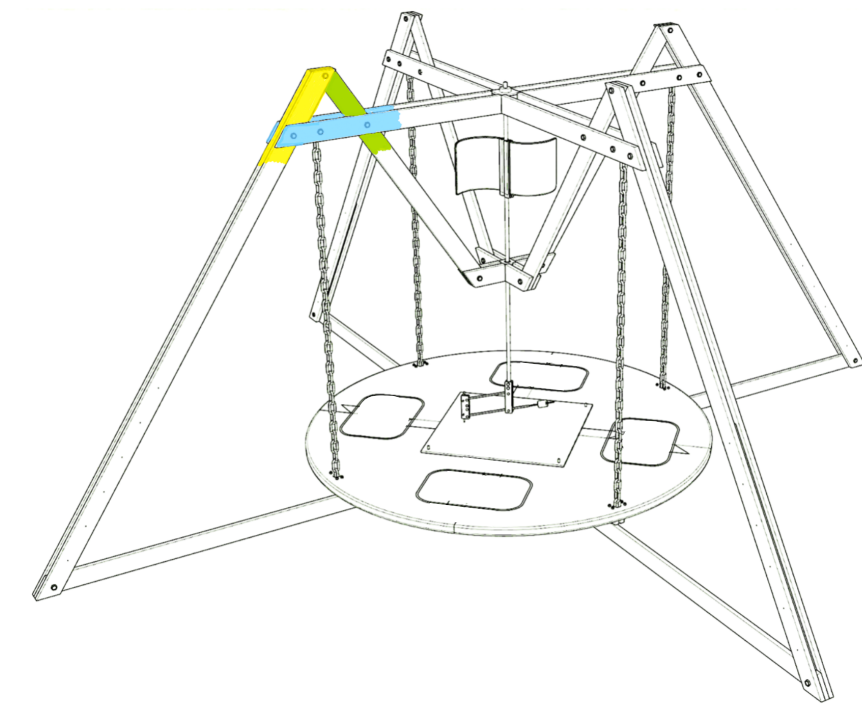

# WIND MECHANISM

Wind Mechanism

1:5  
100mm  
0

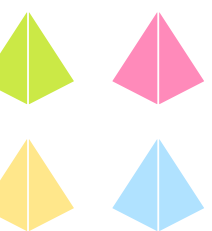
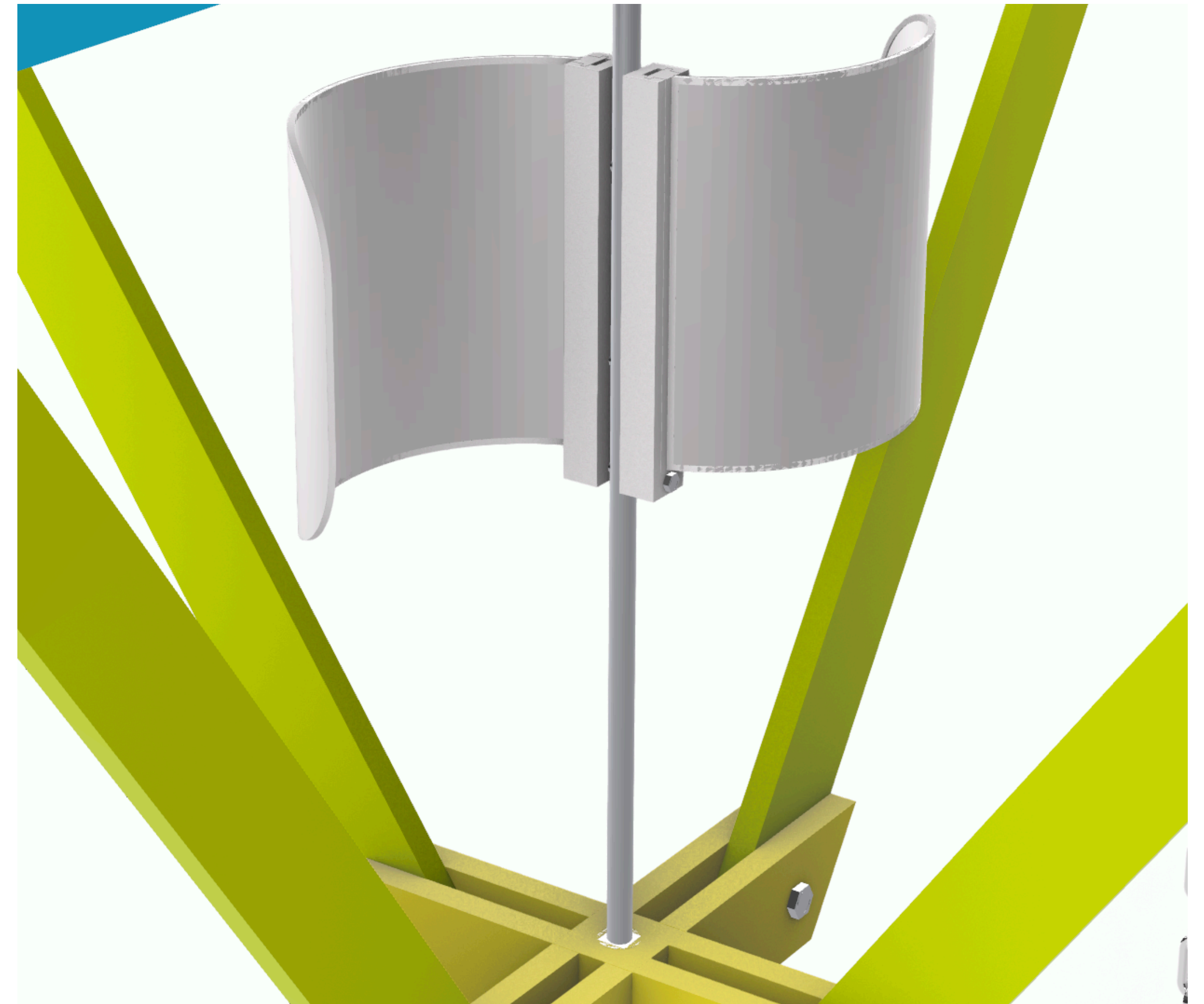
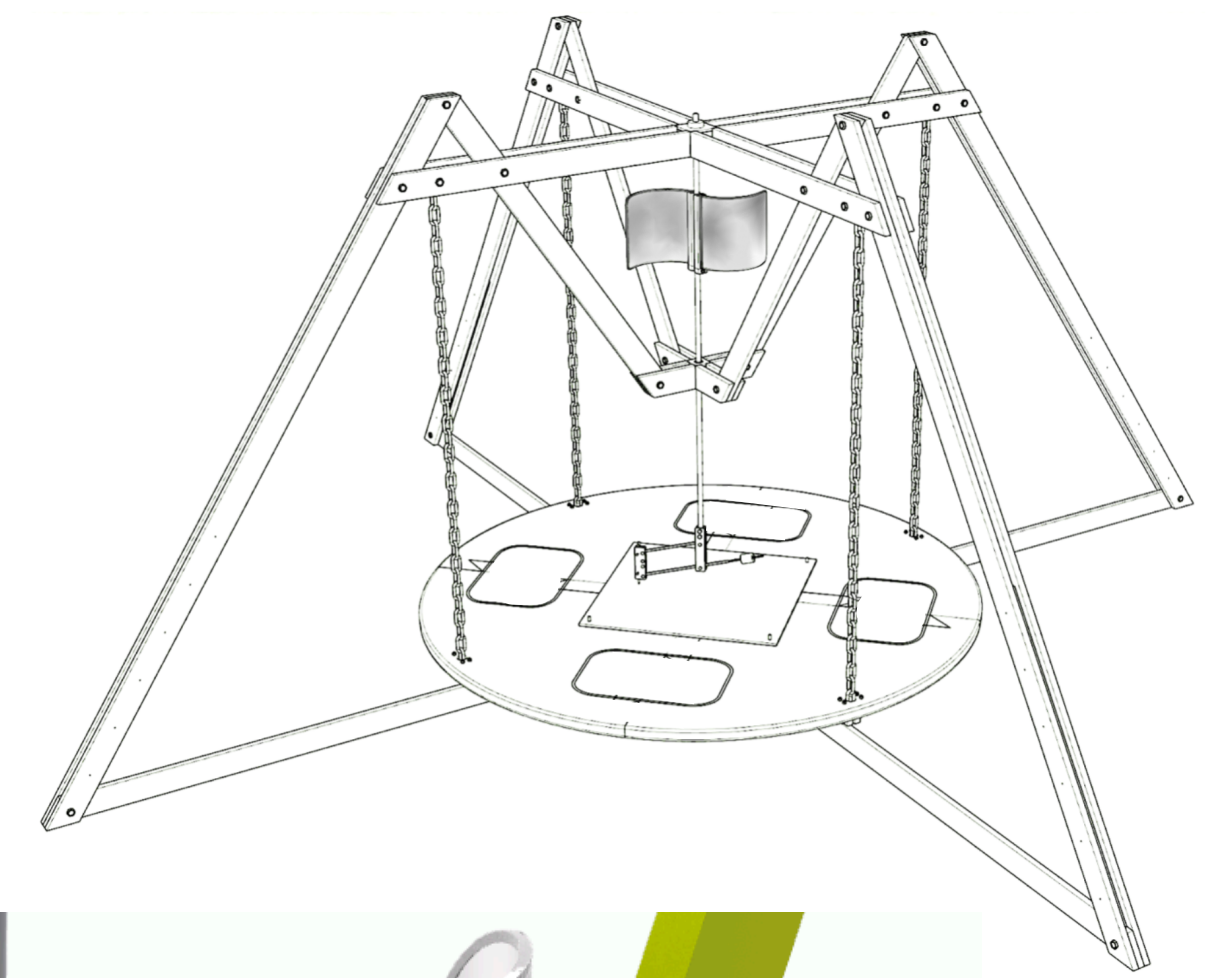
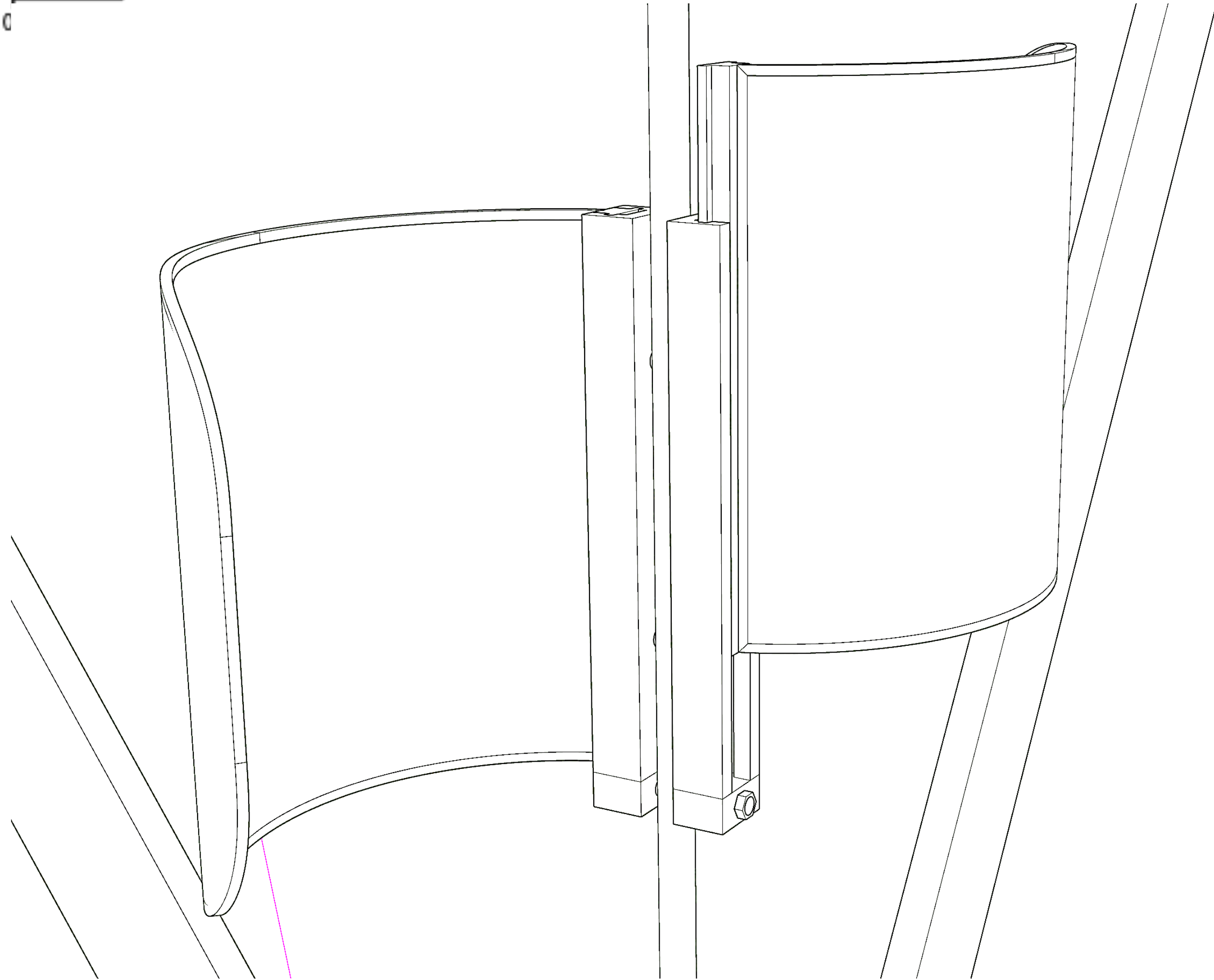

# PEN MECHANISM

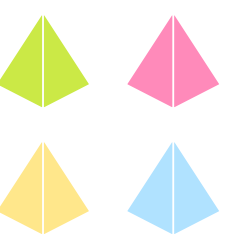
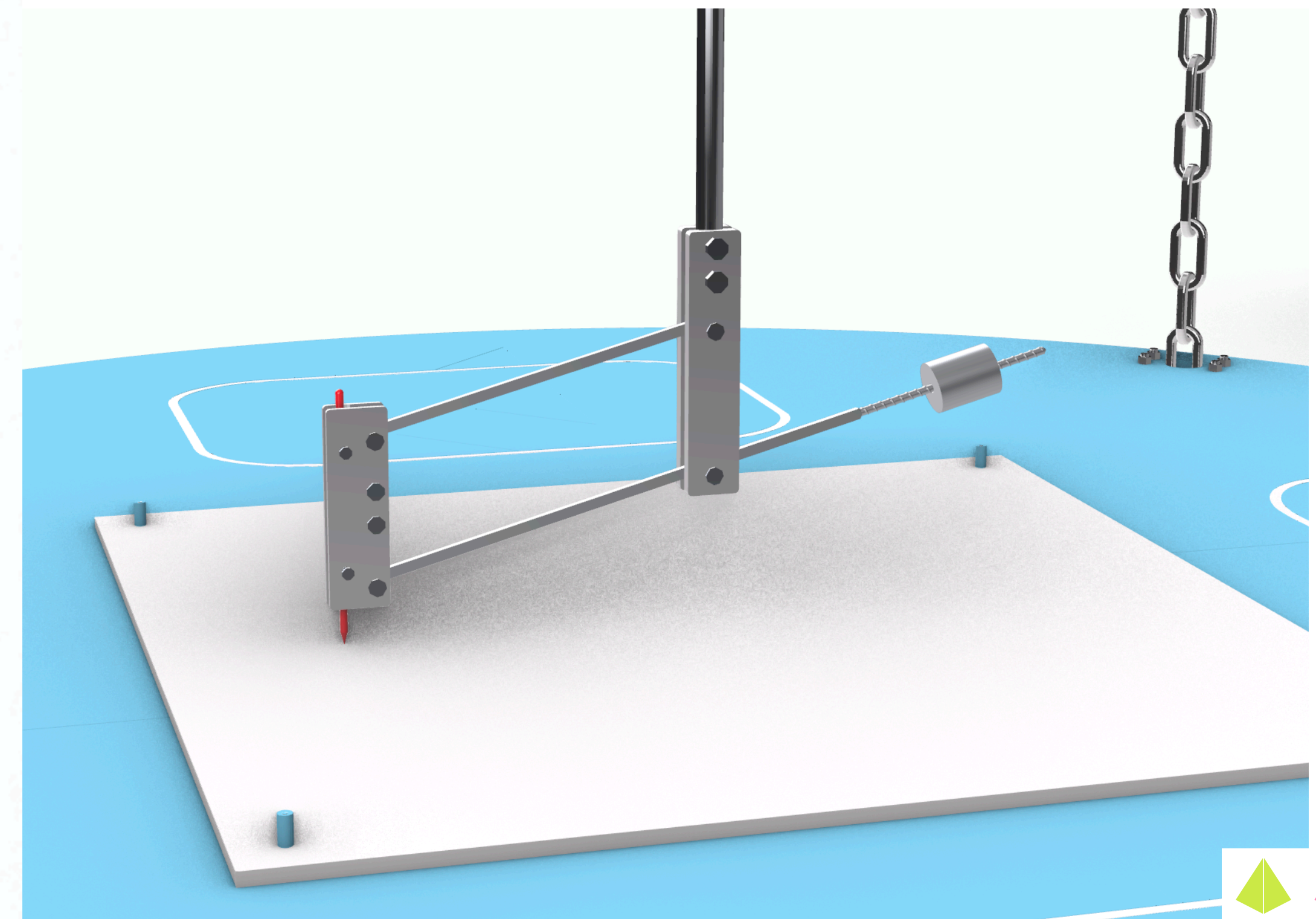
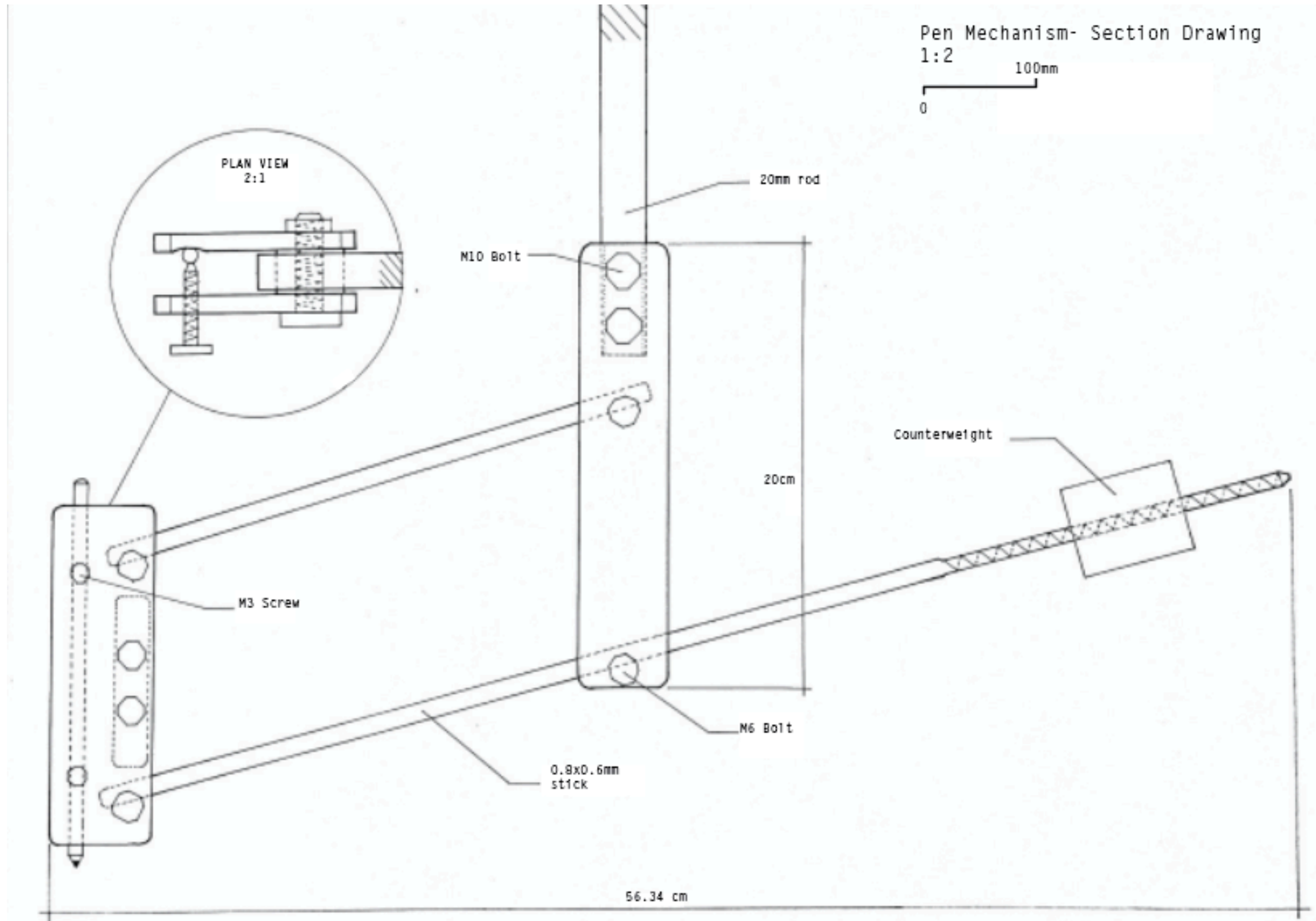
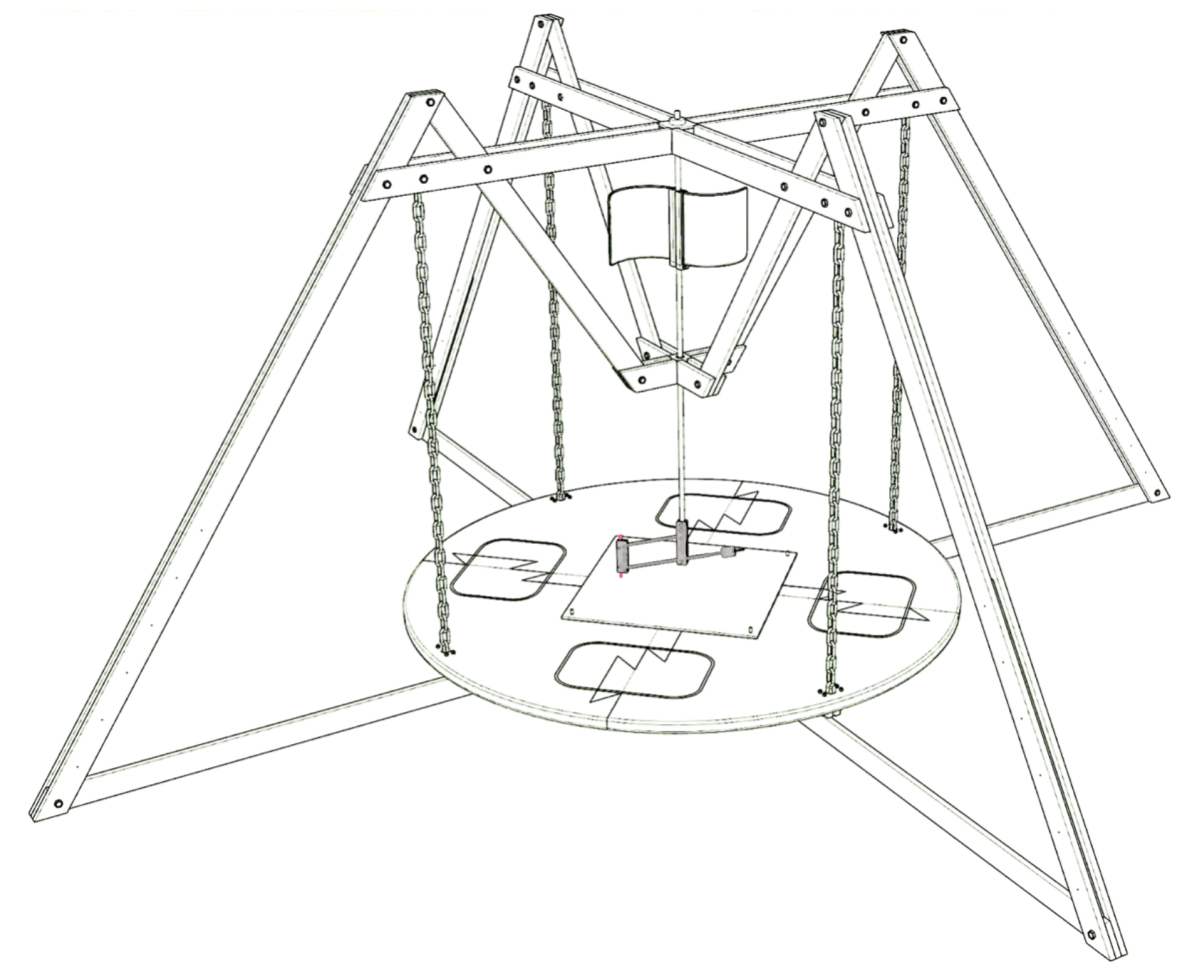

COLOUR

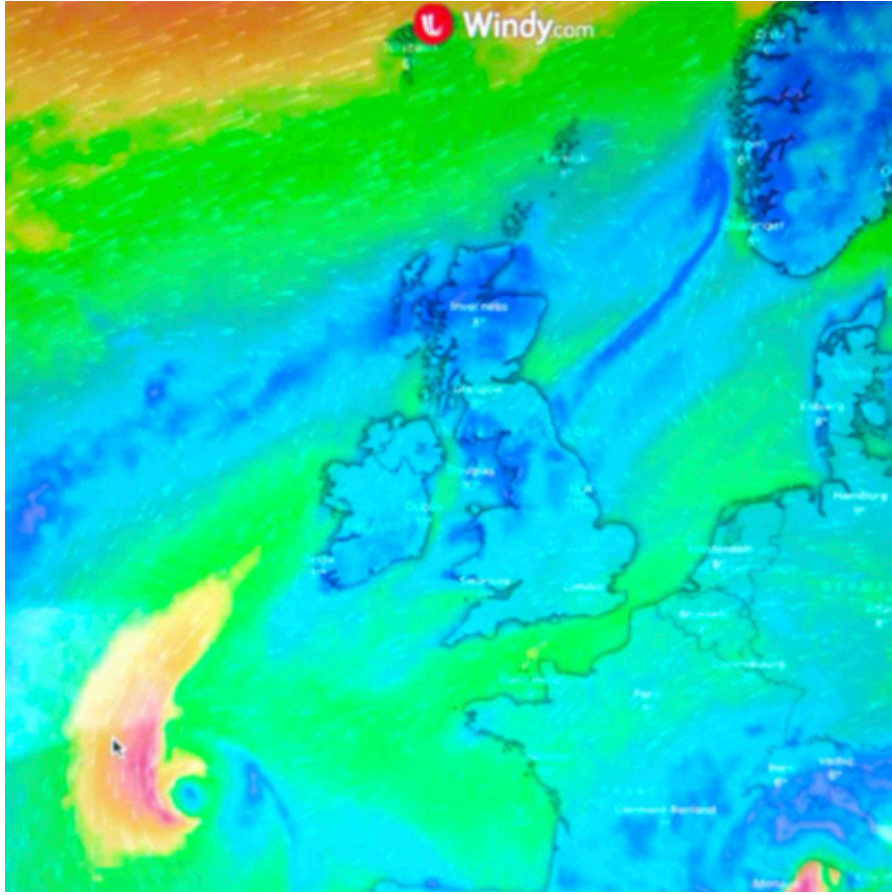
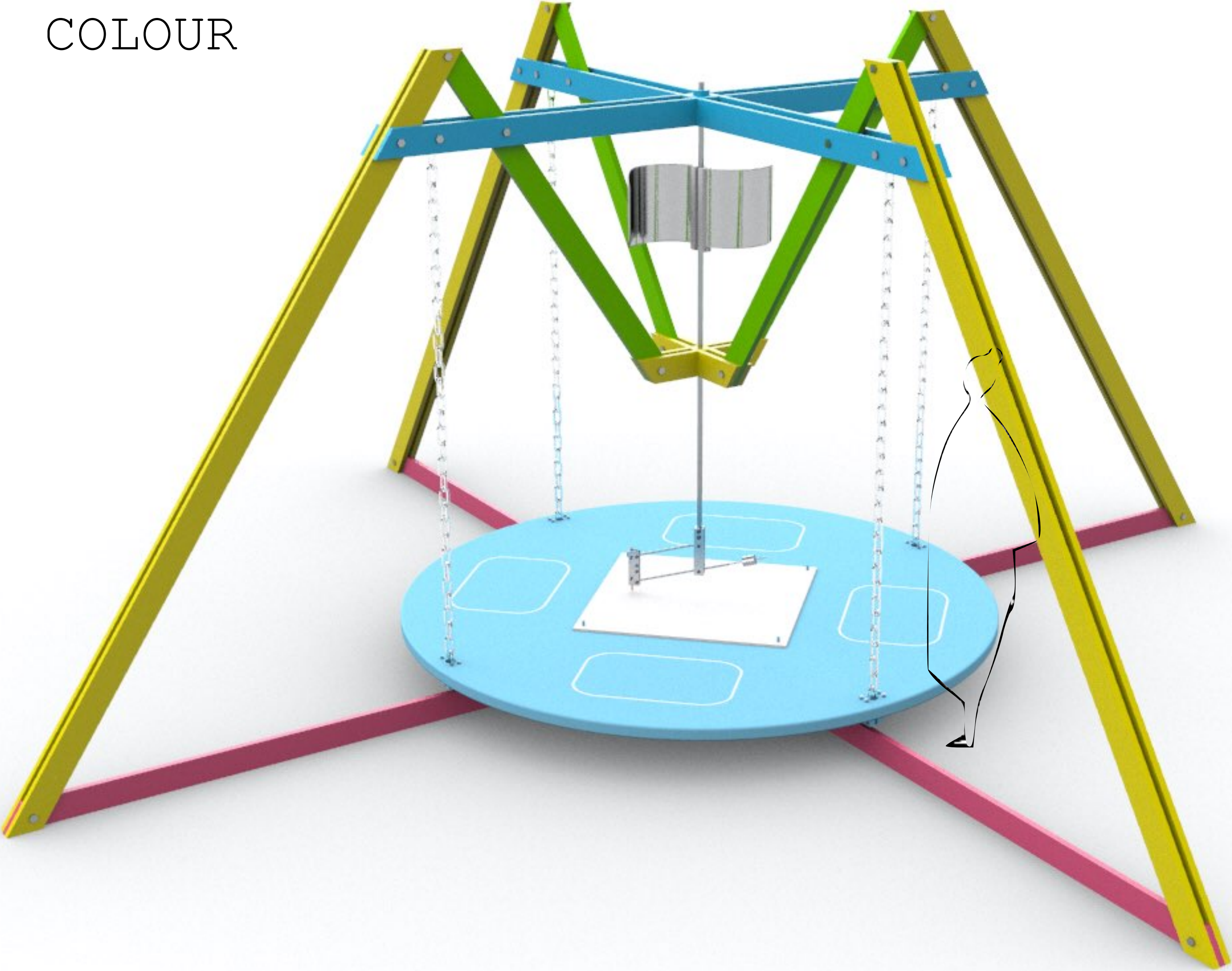

Toshiko Horiuchi MacAdam

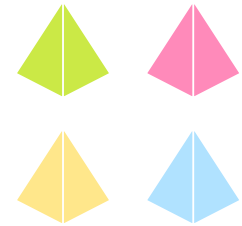

# SITE PLAN

Here East, Stratford

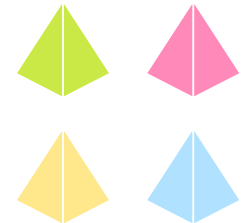
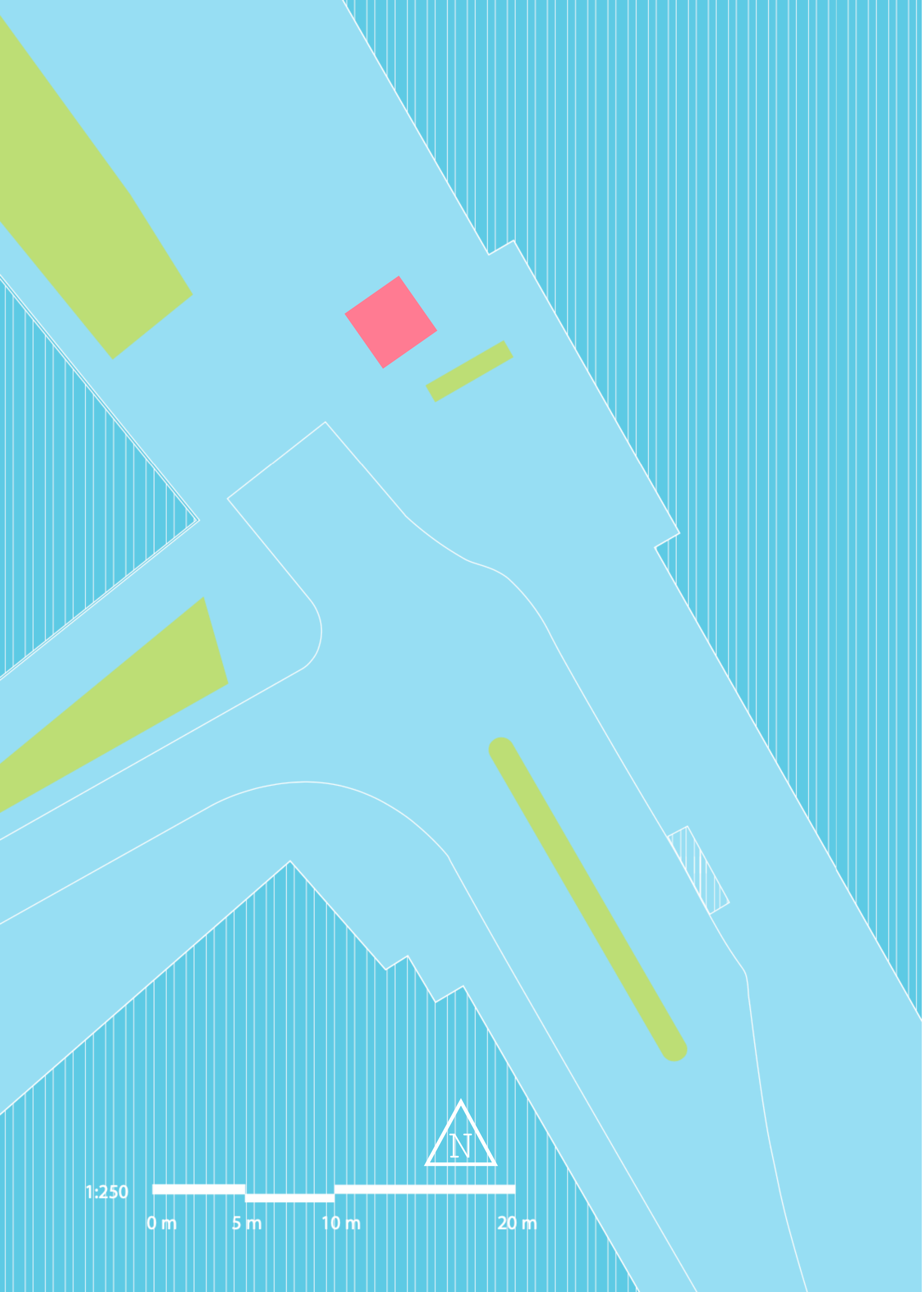

# SITE ANALYSIS

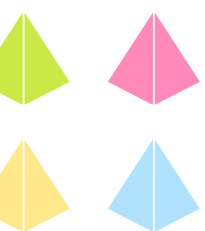
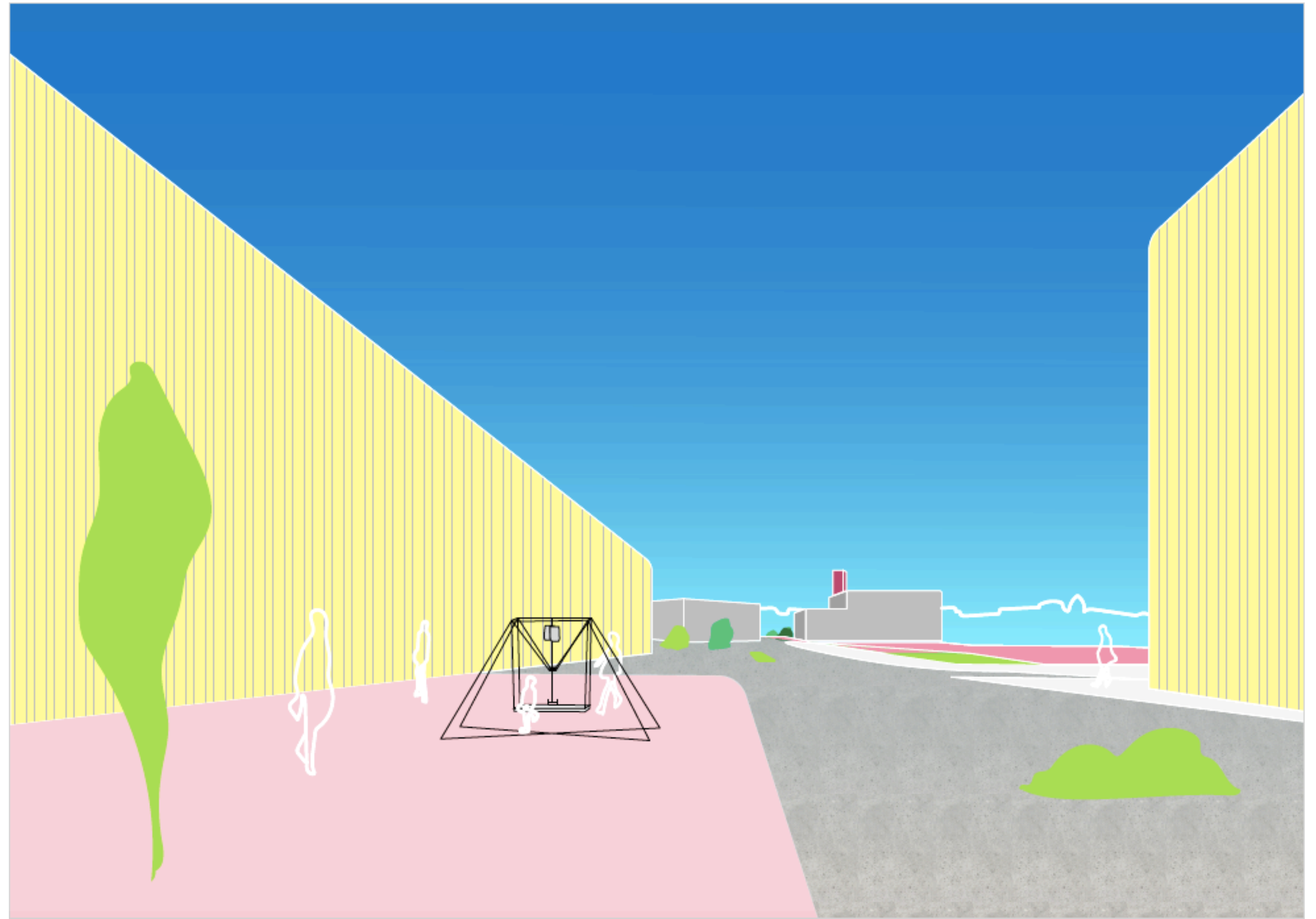
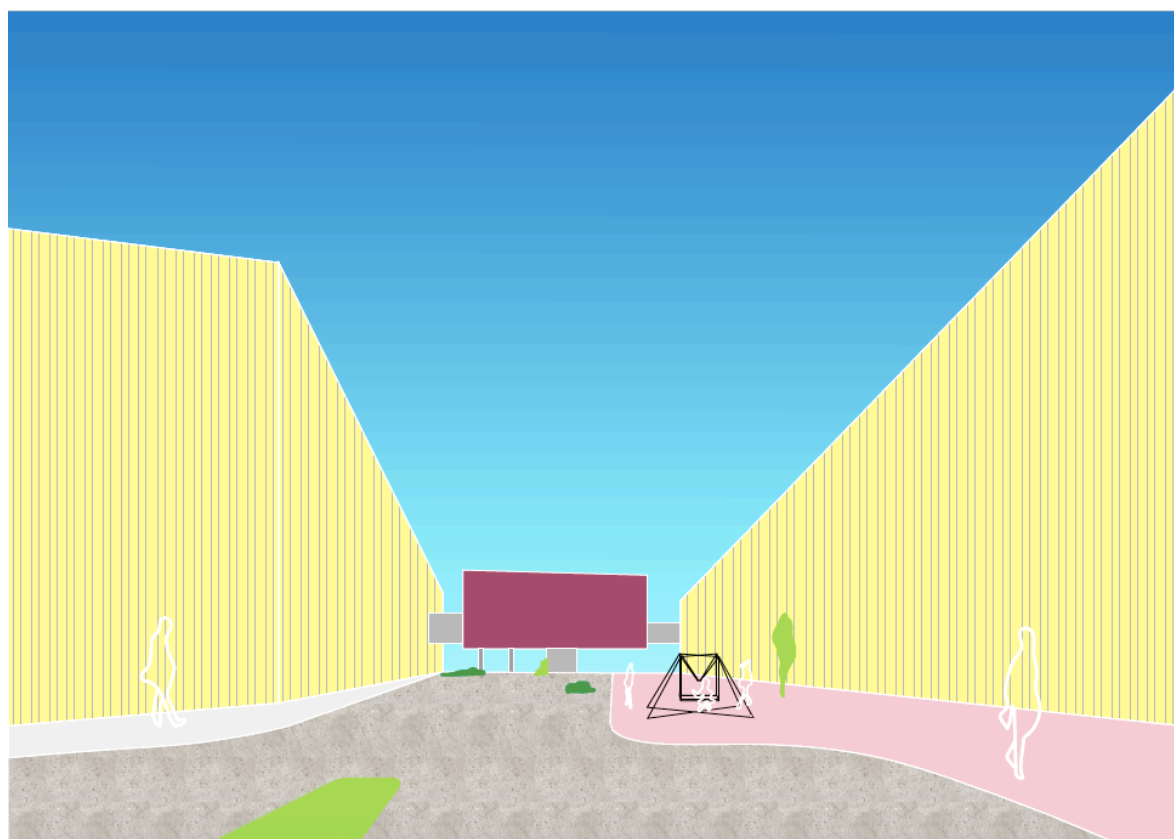
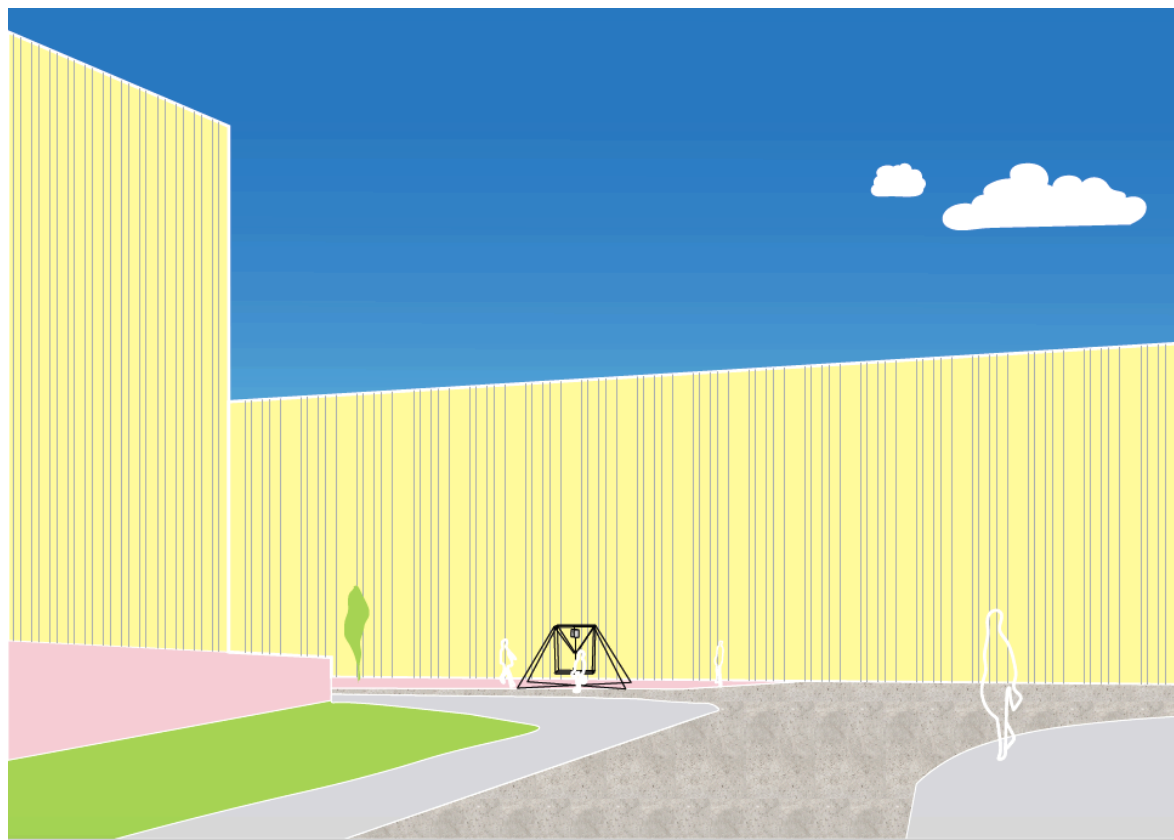

# PEDESTRIAN MOVEMENT

Here East, Stratford



# ENVIRONMENTAL ANALYSIS

Here East, Stratford

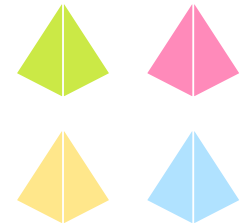

# POSSIBLE INTERACTIONS

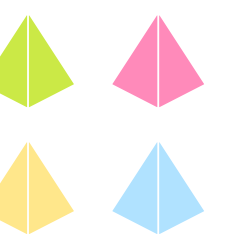

# ONE-PERSON INTERACTION

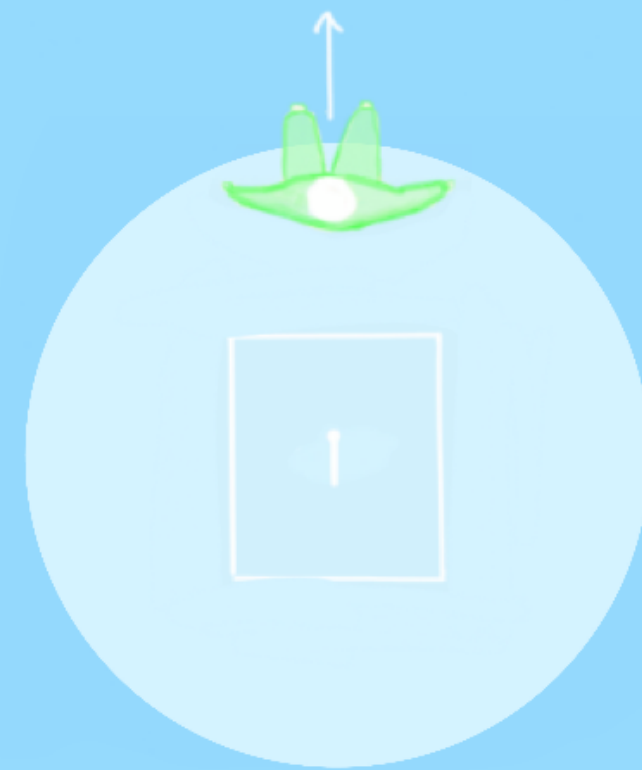

WIND



NO WIND

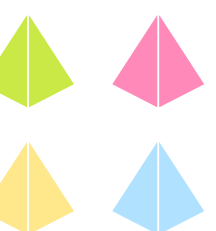
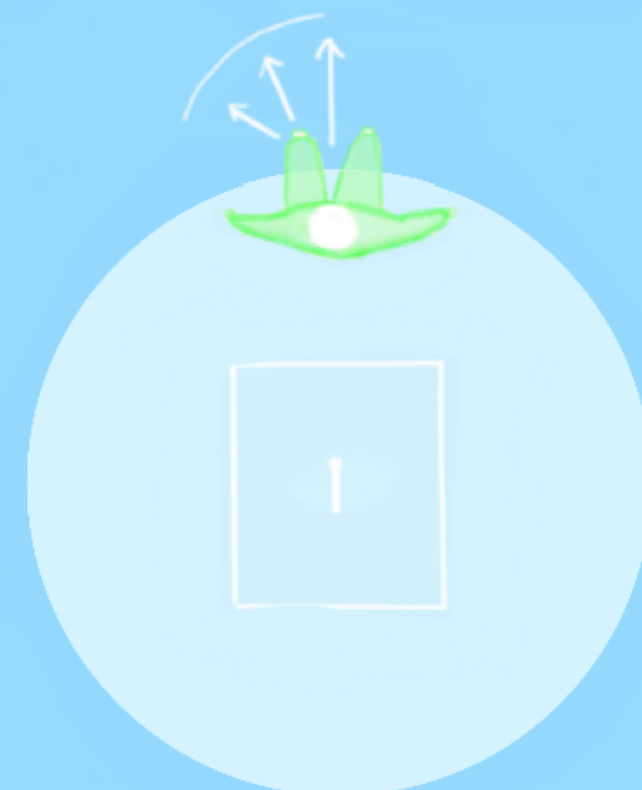
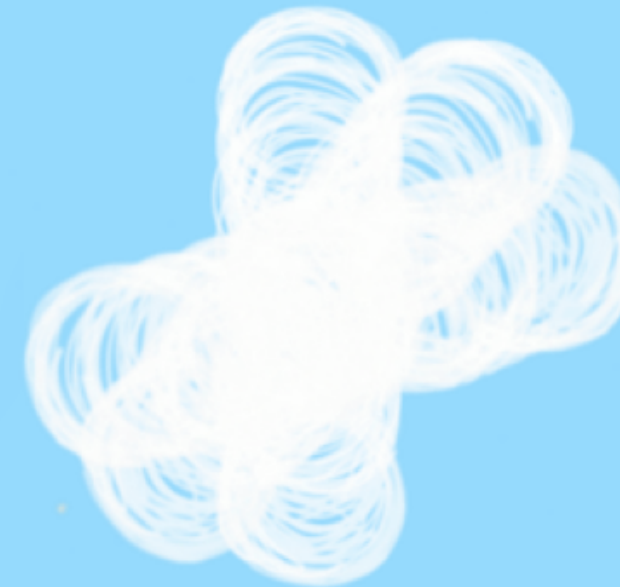
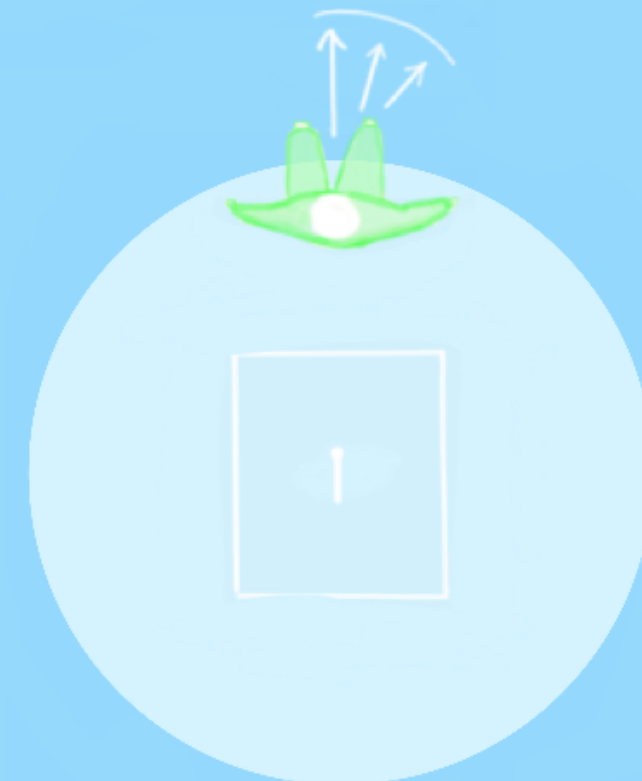

# MULTI-PEOPLE INTERACTION

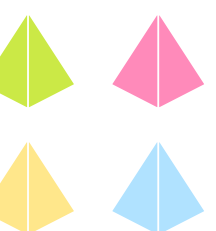
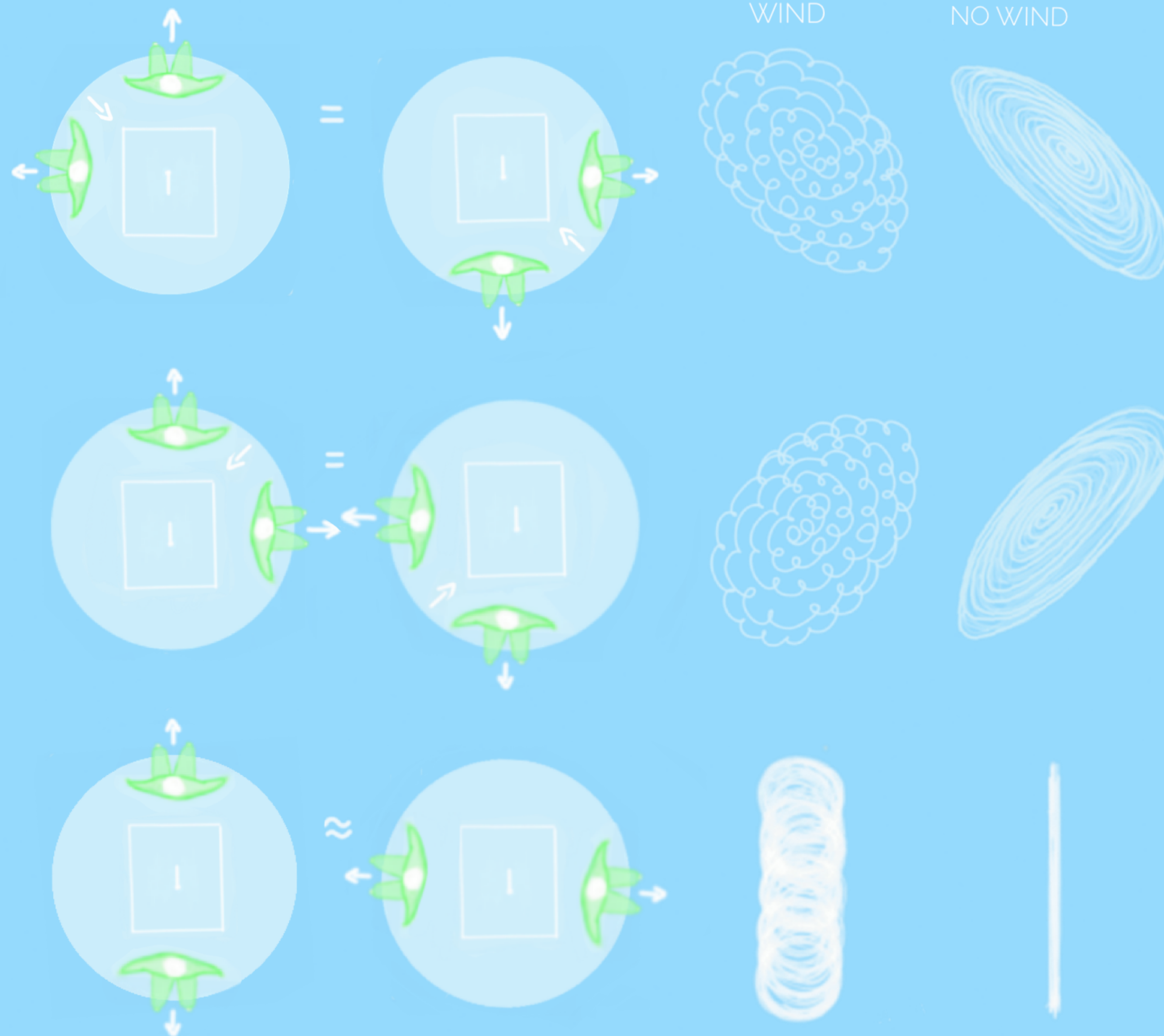

# WIND INTERACTION

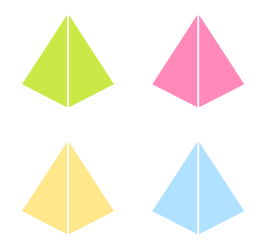
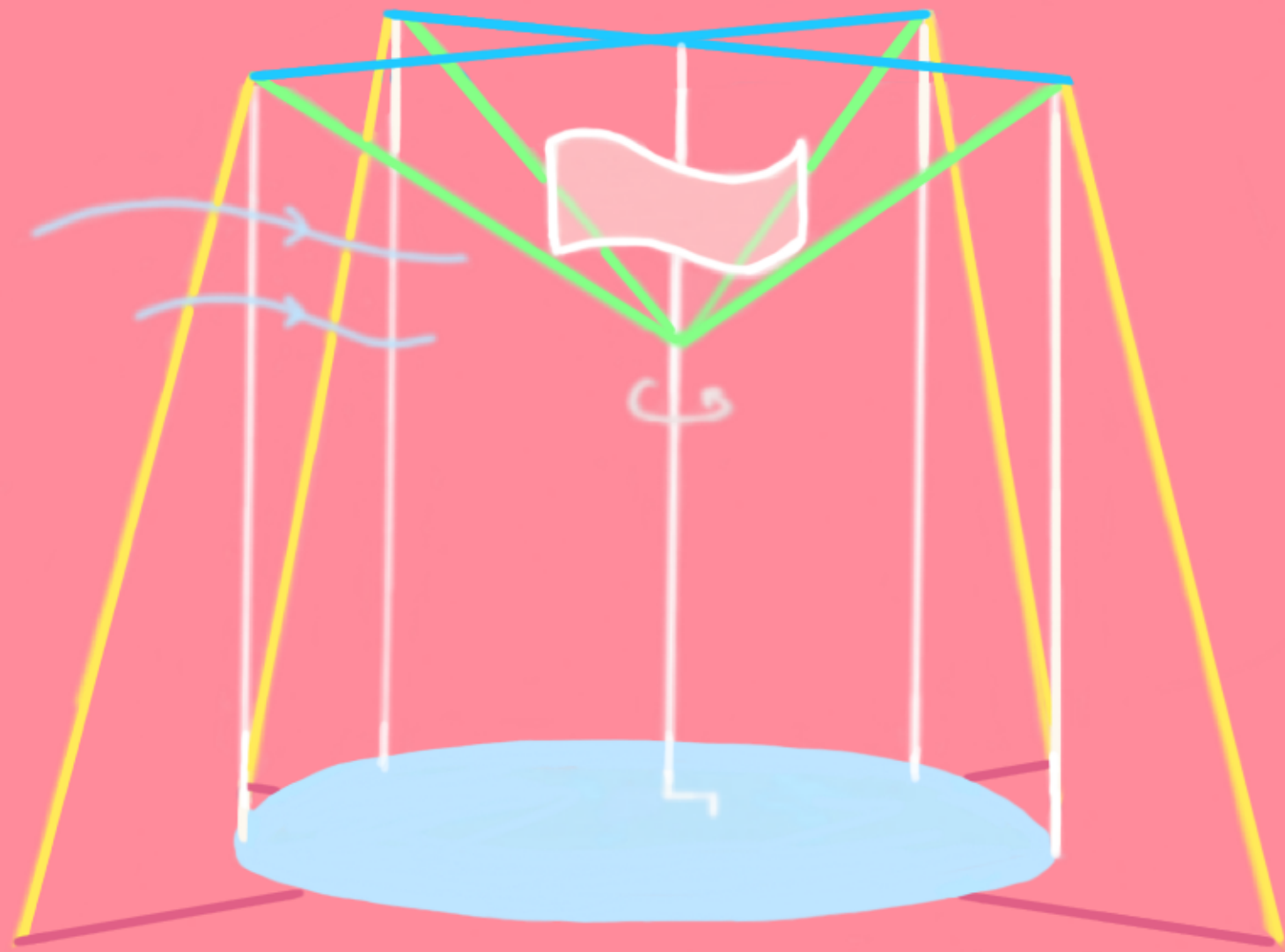

# "AFTER" PROCESS INTERACTION

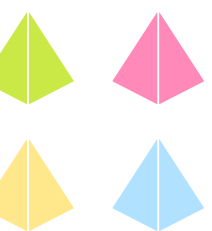

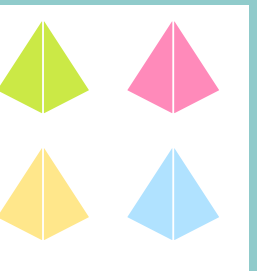
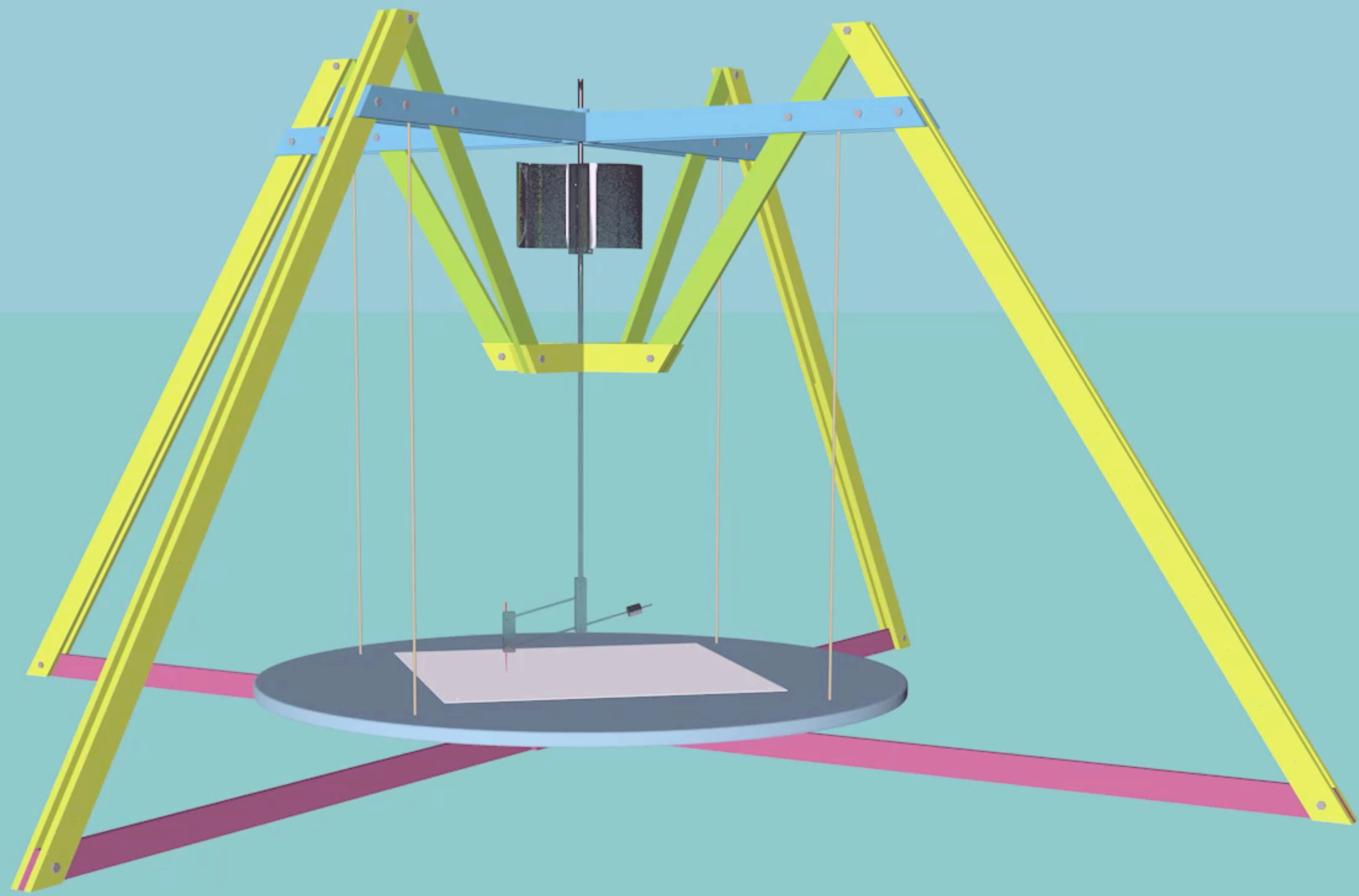

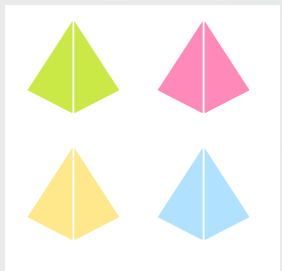
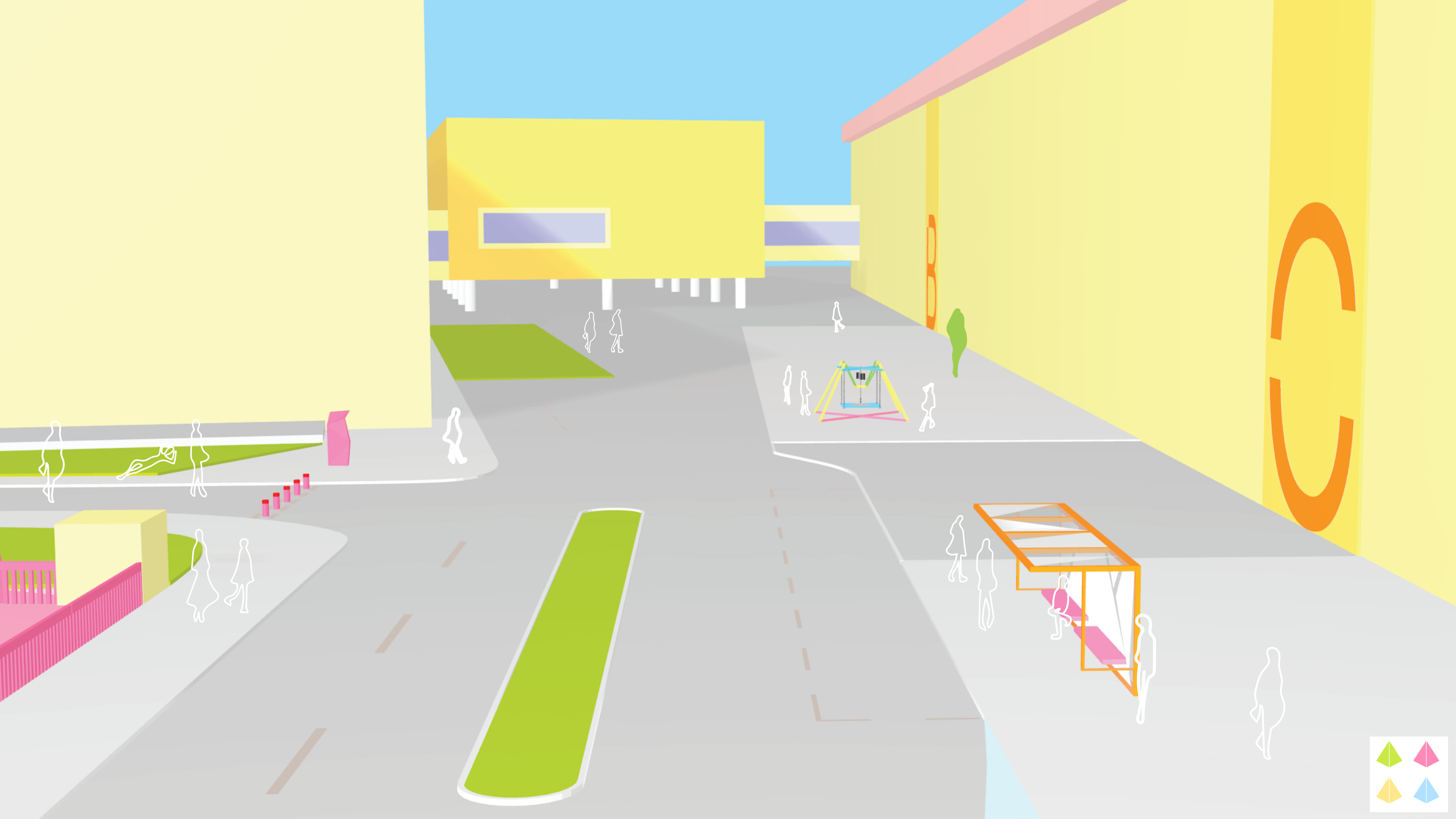



-  parks
-  schools
-  attractions
-  offices



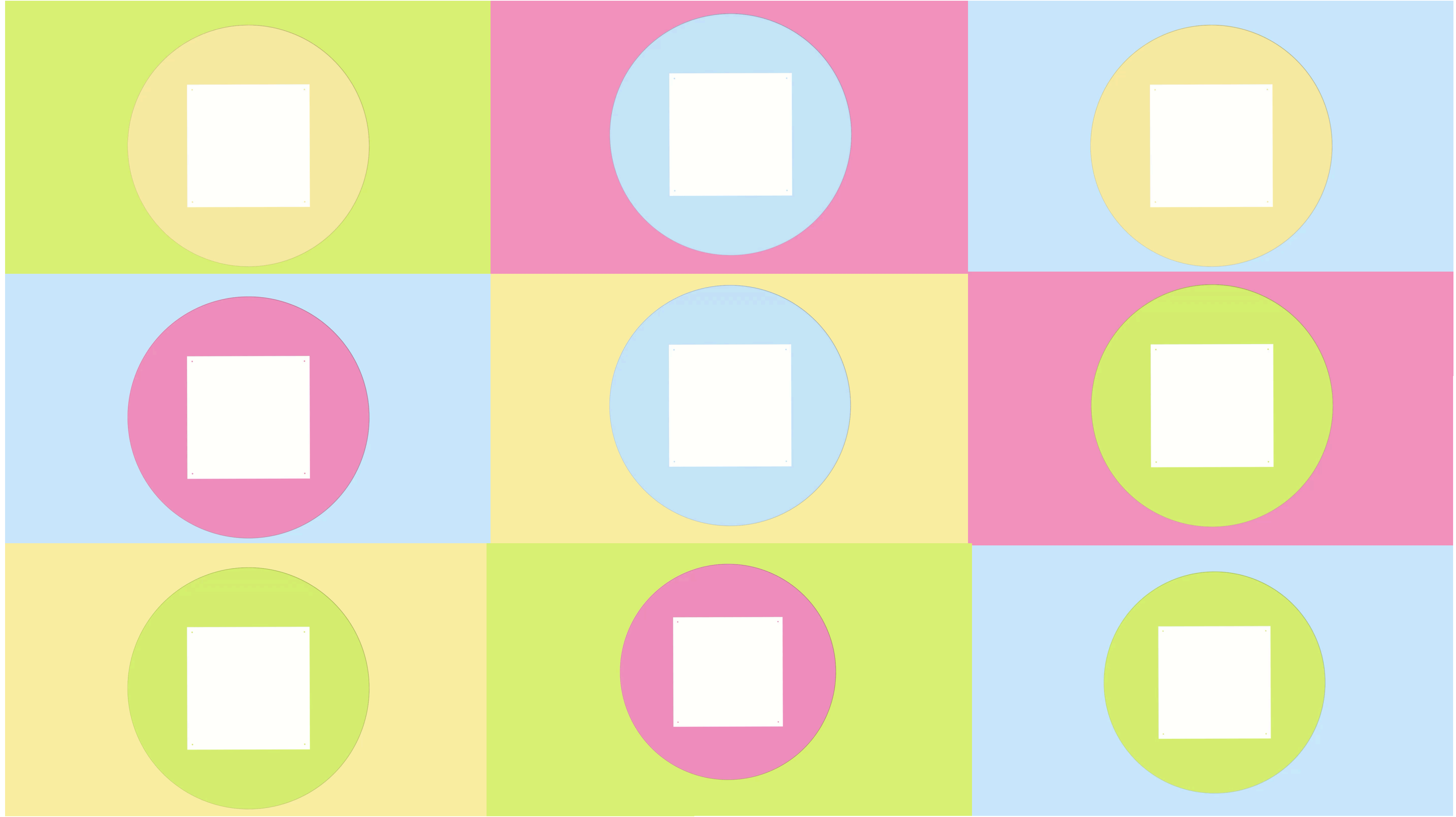

POSSIBLE INTERACTIONS

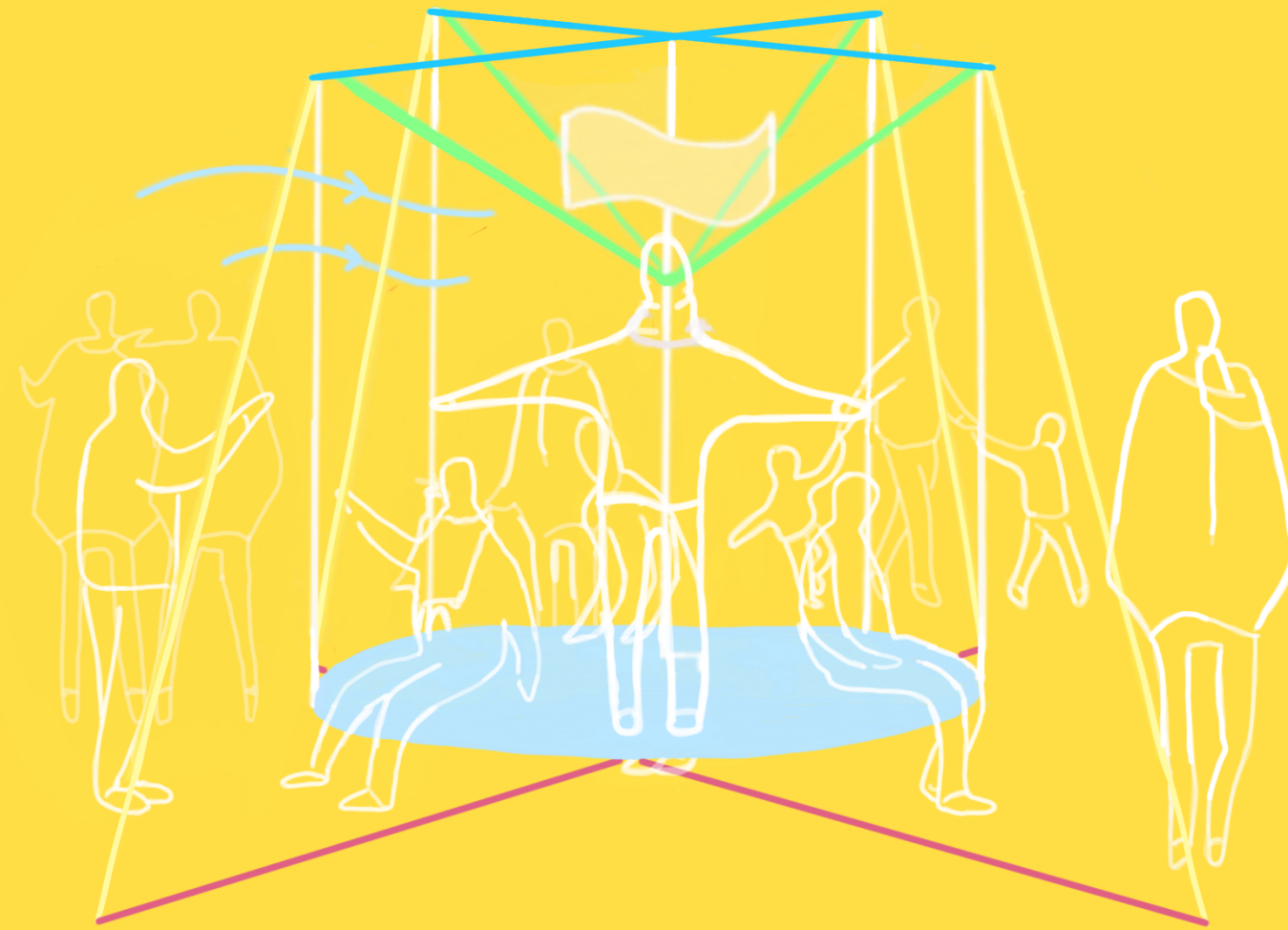

WIND INTERACTION

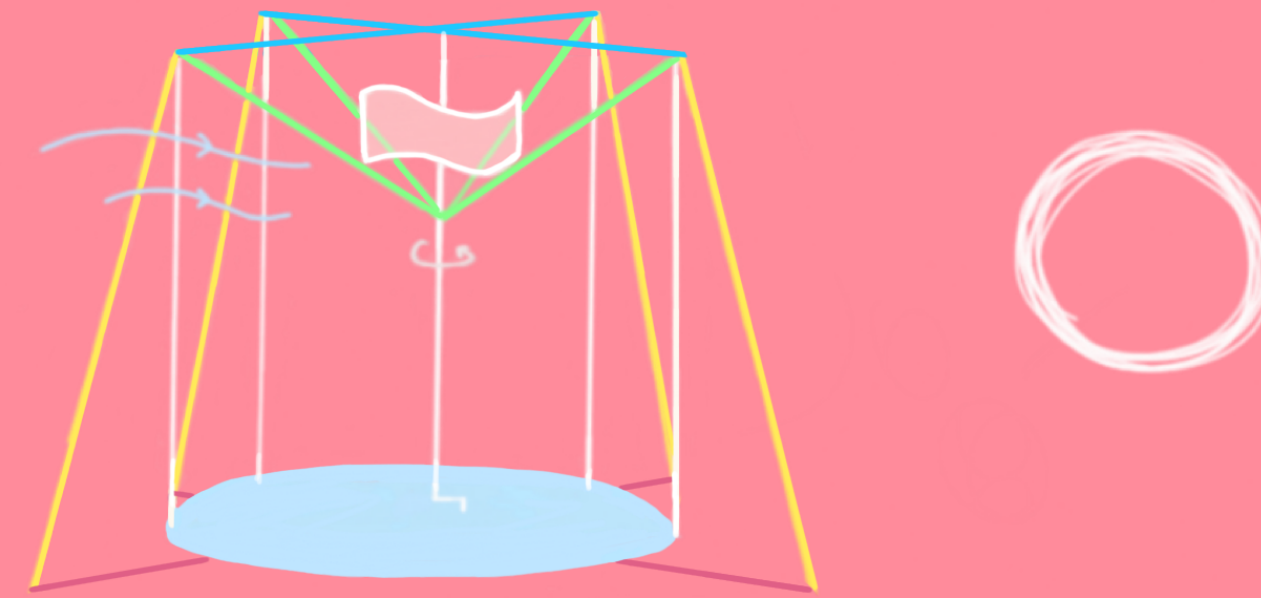

"AFTER" PROCESS INTERACTION

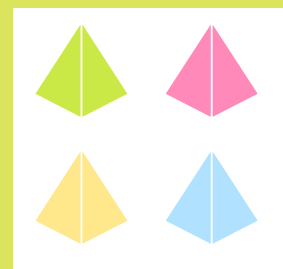
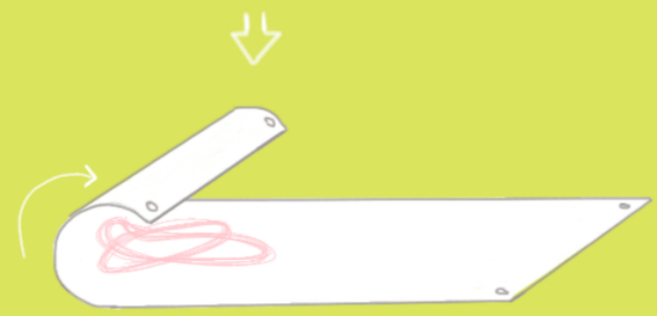
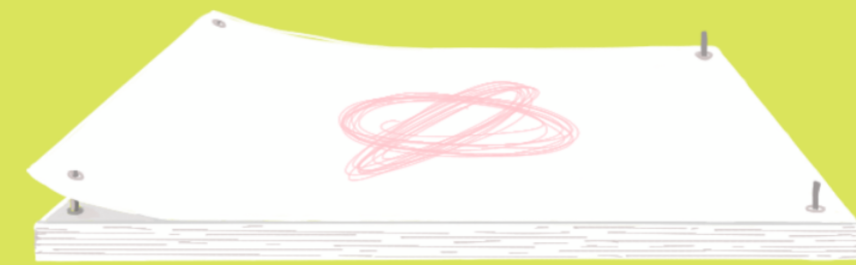

MULTI-PEOPLE INTERACTION

